



The British Amateur Television Club

CQ-TV

No. 283 – Spring 2024



Introducing the PicoTuner

BATC shop EU warehouse

**Surfacemount Pico adaptor for
the MiniTioner V2 PCB**

**Going digital with two
triple Ryde receivers**

**Cheap video cameras with
poor colour reproduction**

The Portsdown Newsletter

**Impact of Amp
Over-drive on DATV?**

Portable DATV at GX3WIM/P

Poor man's bandviewer

The Portsdown noise meter

**Modifications to the
Polycom VTC Table Microphone**

**32dB RF attenuator – an
alternative solution**

... and much more inside!

CQ-TV 283

Contents:

- 3 From the Chairman...
- 4 The Listing - new and renewing members
- 5 Activity and Contests
- 6 HamTV update
- 7 The BATC general meeting 2024
- 8 Financial report
- 10 Introducing the PicoTuner
- 11 A new PCB for the PicoTuner
- 12 BATC shop EU warehouse
- 12 Surface mount Pico adaptor for the MiniTouner V2 PCB
- 13 Going digital with two triple Ryde receivers
- 16 Cheap video cameras with poor colour reproduction
- 17 The Portsdown Newsletter
- 19 Impact of Amp Over-drive on DATV?
- 20 Portable DATV at GX3WIM/P
- 21 Poor man's bandviewer
- 22 The Portsdown noise meter
- 24 Modifications to the Polycom VTC Table Microphone
- 26 32dB RF attenuator – an alternative solution
- 27 ... And Finally... the answer
- 29 Turning Back the Pages



President: David Mann, G8ADM

Chairman: Martin Charman, G4FKK
Club affairs.
Email: chair@batc.tv

General Secretary: Noel Matthews, G8GTZ
General club correspondence and business.
ETCC Liason
Email: secretary@batc.tv

Shop/Members Services: Noel Matthews, G8GTZ
Email: shop@batc.tv

Hon. Treasurer: Dave Crump G8GKQ
Enquiries about club finances, donations,
Club Constitution; and Technical queries.
Email: treasurer@batc.tv

Contests: Clive Reynolds G3GJA
Email: contests@batc.tv

Digital Architect: Phil Crump M0DNY
Email: phil@philcrump.co.uk

CQ-TV Editor: Frank Heritage, M0AEU
Email: editor@batc.tv

Repeaters: Clive Reynolds, G3GJA

Publicity/Social media: Ian Parker, G8XZD
Email: publicity@batc.tv

Membership: Tony Stone, G3UIS
All membership inquiries including new applications,
current membership, non receipt of CQ-TV,
subscriptions.
Email: memsec@batc.tv

BATC Online

Website: <http://www.batc.org.uk>
BATC Wiki: <https://wiki.batc.org.uk/>
Forum: <https://forum.batc.org.uk/>
Stream: <https://batc.org.uk/live/>
Dxspot: <https://dxspot.batc.org.uk/>
YouTube: <https://tinyurl.com/BATCYouTube/>

Contributions

Contributions for publication or for constructive comment are welcome. The preferred method of communication is by email; all relevant committee email addresses are published in CQ-TV.

Alternatively you can write to us at:
BATC Secretary, 12 Petrel Croft, Kempshott,
Basingstoke, Hampshire, RG22 5JY, UK

Contributing authors should note that we aim to publish CQ-TV quarterly in March, June, September and December.

The deadlines for each issue are:
Spring - Please submit by February 28th
Summer - Please submit by May 31st
Autumn - Please submit by August 31st
Winter - Please submit by November 30th

Please submit your contribution as soon as you can before the deadline date. Do not wait for the deadline if you have something to publish as it is easier to prepare page layouts where we have contributions in advance.

Contributions can be in almost any file format - except Microsoft Publisher! MS Word is preferred. Pictures should be submitted in high quality as separate files. Pictures embedded in a file are difficult to extract for publication however if you do wish to demonstrate your completed layout, a sample of your finalised work should be submitted at the same time.

Please note the implications of submitting an article detailed in the 'Legal Niceties'

Legal Niceties (the small print)

E&OE. Whilst every care is taken in the production of this publication, the editor, contributors and the BATC accept no legal responsibility for the advice, data and opinions expressed within. The BATC neither endorses nor is responsible for the content of advertisements. No guarantee of accuracy is implied or given for the material herein. The BATC expressly disclaims all liability with regard to reliance upon any information within this magazine. For example, regulations for the operation of radio frequency equipment vary in different countries. Accordingly readers are advised to check that building or operating any piece of equipment described in CQ-TV will not contravene the rules that apply in their own country. The contents of this publication are covered by international copyright and must not be reproduced without permission, although an exception is made for not-for-profit publications (only) wishing to reprint short extracts or single articles and then only if acknowledgment is given to CQ-TV.

Apart from any fair dealing for the purposes of published review, private study or research permitted under applicable copyright legislation, no part of this publication may be reproduced, stored in a retrieval system or transmitted in any form by any means without the prior permission of the BATC.

All copyrights and trademarks mentioned in this publication are acknowledged and no infringement of the intellectual copyright of others is intended. Authors must ensure that they have relevant permissions in place where copyright material is reproduced or where reference is made to individuals, websites and email addresses.

Printed in Great Britain. ISSN 1466-6790

© Copyright BATC & Contributors 2024



From the Chairman...

Martin Charman G4FKK

The BATC has been very busy since the last CQTV. Our specially made for us by Serit, FTS 4334 NIMs finally got to us in February and are now available in the shop. Despite being around twice the price of the previous batch, for all the reasons outlined in Noel's article in the last CQTV, they seem to be selling like hot cakes and I'm hoping they will be being put to good on-air use. See Dave's PicoTune article later in this issue which should help mitigate the NIM price increase.

I'd like to thank Benno, PA3FBX, who has volunteered to make most of the BATC shop items available directly from the Netherlands for our European members. This has sped-up delivery times to the EU considerably and has lightened the load on Noel, our "UK branch" shop manager; during the rush for the new stock of NIMs. Great work Benno, we are all very grateful.

Your committee has been drawing up plans for CAT24 which this year will incorporate the Biannual General Meeting, the official notice for which appears elsewhere in this issue. If you're interested in joining the committee please note the procedure as outlined in the notification and get your proposed and seconded application in sixty days before the BGM.

If things at SpaceX go according to plan, the upgraded HamTV equipment should blast off to the ISS on 21 March. There's further information on this in this edition of CQTV.

Colin, G4KLB, managed to receive Tim Peake's first HamTV transmission from the ISS, some years ago now, and made a video of how he did it which may inspire you to prepare some gear for when the upgraded system gets fired up – hopefully later this year. Colin's video can be found here. <https://www.youtube.com/watch?v=9keVA2IDPBc>

The rest of the year looks pretty busy too. BATC committee members are planning on attending the following rallies...

14 April	Martlesham MRT
21 April	Norbreck Rally (No BATC shop)
23 June	Newbury Rally
30 June	Dunstable Downs Boot Sale
14 July	McMichael Rally Reading
11 August	Flight Refuelling Rally Wimborne
1 September	Telford HamFest (No BATC Shop)
27/28 September	Newark Hamfest
11/13 October	RSGB Convention Milton Keynes
13 October	Hornsea ARC Rally (No BATC Shop)
November	CATS Bazaar (Possibly no BATC Shop)
December	Midland MRT

So do pop along and say hello if you're also going to be there.

And finally, if you've been busy building things in the shack or you've developed/installed some new production equipment/software, maybe discovered a fantastic new camera or graphics package then drop Frank, our noble CQTV editor; an article for a future edition of CQTV.

Ours can be quite a technical hobby and a lot of articles, quite rightly, can be fairly "RF-centric" but most BATC members will be interested in how the pictures get to the PA stage. Email Frank at editor@batc.tv



73, Martin G4FKK

The Listing

new and renewing members



Tony Stone G3UIS

Over the past couple of months, I have been thinking what the members would be interested in learning from the membership secretary in a regular feature. I believe the most useful information I could provide would be details of our new members who have joined in the past three months since the last issue of the magazine, together with the total number of active members at the beginning of the quarter. The listing therefore has been amended to provide this information and will no longer include membership renewals.

Membership renewals, which previously resulted in member queries asking why they were either included or excluded from the listing, will no longer occur.

Over the past few weeks, I have been staying in southern Spain, where I was delighted to be invited by Michael EA7KIR, to join him in his home for the weekly Q-100 net.

I was made very welcome by Michael and his lovely wife, Pilar, and hopefully our light-hearted banter proved amusing.

I am pleased to report there has been a flurry of new members since the tuners went on sale in our shop. Finally, thank you to all our new members for joining and our longer term members for continuing to support the club. 📡

Belgium		
Pierre Vandamme	ON5PVD	Relegem
Joel Maelfeyt	ON6JM	Moorsele
Canada		
Stefan Wagener	VE4SW	Seven Sisters Falls
Czechia		
Pavel Husak	OK1PHU	Hlinsko
France		
DUPONT sylvain	CN8DN	Bussieres
Germany		
Ferda Erginsoy	DL3FE	Windeck
Alain Lasserre	DD5AA	Dessau-Rosslau
Dr. Roland Zeise	DH4EAK	Minden
Elisabeth Buchner		Abensberg
Mike Kerp	DL1GNM	Waldkirch
Israel		
Doron Shalev	4X1TY	Alfei-Menashe
Italy		
Davide Cuppone	IW9GUR	Catania
Alberto Rogante	IW0HJZ	Rome
Antonino Cacace		Cuggiono
Japan		
Makoto Sakai	JK1DGG	Fujisawa
Spain		
Jose Novillo		Sada
Netherlands		
Onno Beemsterboer	PE1IXL	Strijen

Eric-Jan Wösten	PA0ERC	Best
Harrie Nooij	PE1JXI	Geleen
Lennard Reijtenbagh	PH1LMR	Hellevoetsluis
Hans Kemink	PA1IZR	Fijnaart
Paul Peppelman	pe1avp	Limmen
Roel Ketelaars	PE4W	Oostzaan
UK		
Bill McAleer	G3MMF	Belfast
Paul Tullock	M0DPH	Bridlington
nick passam	M0DSR	blythe bridge
David Chapman	G4PPN	Kingston upon Thames
Ian Bennett	G6HNJ	Boorley Green
Barry Thompson	2E0RNN	Walsall
Christopher Carr	G8CEE	Morton on Swale
Amir Sameny		London
Iain Tennent	M1IAN	Walton on Thames
Ravi Gopan	M0XUU	Reading
Laszlo Sanduly	M0BOY	Milton Keynes
Gerard O'Reilly		Newtownbutler, Enniskillen
USA		
Larry Nelson	K0PYX	Longmont
Christopher Ebert	NA0D	West Fork
William Frovik	N0MNB	Blaine
Harlie Golden	N0VWX	Coaldale
Robert Campbell	KB3PMR	Fredericksburg

Total paid memberships at 1st March 2024: 1398



Activity and Contests

Clive Reynolds G3GJA

Christmas Repeater Contest & Christmas Activity Ladder

Once again, activity on ATV was concentrated in Yorkshire for the Christmas competitions. Ken G8VDP near Barnsley excelled himself to take the top place in the Activity Ladder and the Repeater Contest and will receive a trophy to add to his collection. The new one will be dated 2022 though, as yours truly dropped a clanger and got the date wrong on his trophy for last year, so he has already got one dated 2023!

Activity Ladder			Repeater Contest		
Pos	Callsign	Points	Pos	Callsign	Points
1	G8VDP	90	1	G8VDP	5064
2	MIASR	74	2	G0AZQ	1680
3	G3GJA	73	3	G4EEV	936

All contacts made in the Repeater Contest were through GB3EY in East Yorkshire. The total of 9,959 points is the highest seen in the competition so far. Ken G8VDP contributed more than half of the overall total points, helped by his location being 47 miles from the repeater and notching up 40 QSOs.

The Christmas Activity Ladder produced some contacts that were thought to be impossible due to obstructed paths. In my case, I found it was possible to work Ken G8VDP direct, despite my QTH being only 4m ASL and a 90m high hill in the way at 6km distant. The Activity Ladder encourages activity as well as pushing the boundaries of what is possible with DATV; I encourage all of you to try it this year.

Annual Activity Ladders

The 2023 70cm Activity Ladder has been won by David M0YDH and the 6cm Activity Ladder by Chris G4AYT. Chris's entry listed 50 QSOs, showing that with perseverance relatively short distance QSOs can win a first place on the Ladder.

5.6GHz			70cm		
Pos	Callsign	Points	Pos	Callsign	Points
1	G4AYT	739	1	M0YDH	293
2	G4ASR/P	528	2	G0AZQ	68
3	G8NAV	442	3	G6PKS	66

Activity Weekends

No reports of activity were received for the January and February Activity Weekends. Hardly surprising considering the weather! However, yesterday the 17th March saw Rob head out to the North York Moors for the 2m focused weekend and was rewarded with some QSOs to Dave G4EEV in Bishop Thornton, Barry G4ZCN and myself in Hull. Rob was running just 6W, giving an MER of 5.2dB for his 333kS/s, FEC1/2 signal in Hull over a distance of 80km.



▶ Rob M0DTS portable on the North York Moors on 2m, and below, a map of his contacts

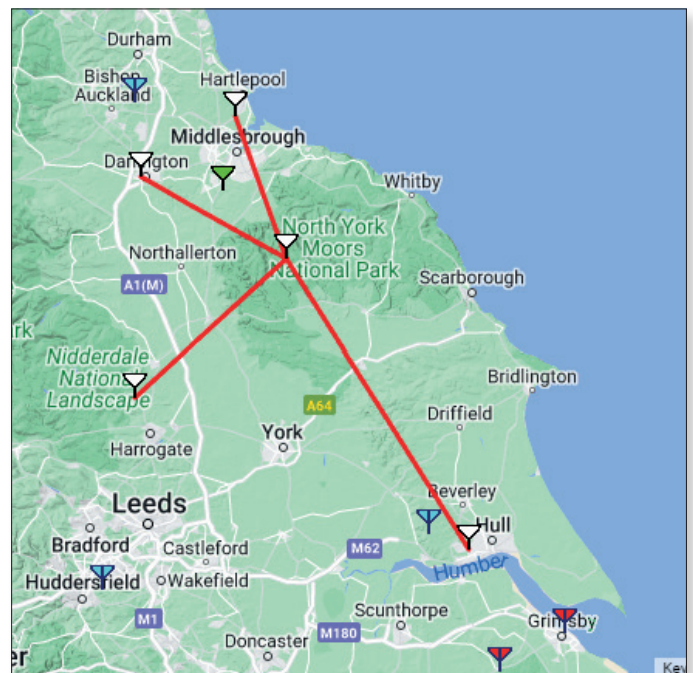

These are the Activity Weekend dates for the rest of the year:

April 13th/14th	70cms.
May 11th/12th	All bands (IARU preparation).
June 8th/9th	IARU Region ATV Contest.
July 6th/7th	2m, 4m and 6m.
September 7th/8th	13cms and up
October 5th/6th	70cms.
November 2nd/3rd	2m, 4m and 6m
November 30th/ December 1st	All bands

Repeater Roundup

GB3EY near Hull was taken off air in mid-January to have a major upgrade. It is the first repeater in the country to use the BATC Repeater Controller on air. Written by Dave G8GKQ, it runs on a Raspberry Pi4 and provides the necessary controls to operate the repeater, a slide show whilst idle and an FM transmission on 144.75MHz is relayed by EY during the slide show. The BATC streamer is fed with an HD signal and the Pluto modulator has a full HD feed.

The results have been very well received, especially as the spurious noise on the audio and video caused by ground loops in the analogue logic have been eradicated.

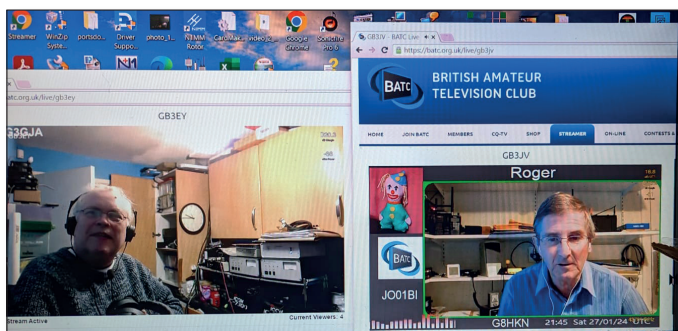

Shortly after returning to service, Bob G7AVU in Gainsborough was seen on EY; it's great to have Bob back on the air following his illness and we look forward to seeing more of him.



▶ Bob G7AVU

The following day I had a QSO with Roger G8HKN in Orprington. We were both transmitting to our local repeaters and using the BATC streamer to receive each other. Roger was using GB3JV and I was using GB3EY. Not that remarkable perhaps, but it shows how useful the streamer can be and it was great to catch up with Roger after more than 50 years when we were at college in Rochester.

South Yorkshire group continue to make progress with the equipment from GB3YT. Faults have been found on two of the media players and replacements sourced. The high SWR on the antenna has been fixed and another DTX I found to replace the intermittent one. Preamp, filters and duplexer remain on the list of items to be checked.

▶ Left: G3GJA and G8HKN

HamTV update

It is looking very likely that the HamTV unit will arrive back on the ISS before the end of March 2024 – while this is great news it may be some time before the unit is commissioned and ready for use again.

If you are wondering what's involved in receiving HamTV, take a look at the article in CQ-TV 279. Plus we have updated the BATC wiki with details on how to receive the HAMTV signals.

https://wiki.batc.org.uk/HAMTV_from_the_ISS

We look forward to publishing your stories and reports on what success you had.

CRS SpX-30 sked for 21-March

HamTV going up along with plant science, a cube-sat project, and a nanoparticle investigation.



ARISS Photo

HamTV installation date is not yet scheduled. It will downlink video on 2.395 GHz.





The BATC general meeting 2024

This is the official notice to members that the next BATC general meeting will be held at the Midland Air Museum on Sunday 4 August 2024 at 11:30 am.

How often does BATC hold a general meeting?

Our constitution does not specify exactly how often meetings should be held but that they should be normally at intervals of two years, but not exceeding three years. The last GM was held in August 2022 therefore we will hold the next one on Sunday 4 August at 11:30 am during CAT24.

What happens at the GM and how long does it last?

Normally there will be a chairman's report and the treasurer will give an update on the financial state of the club. Then any BATC awards and contest certificates/awards will be presented and finally there will be the committee member elections. The meeting will typically last an hour.

Who can be a committee member?

Any member - the BATC can have up to 10 committee members, including officers, who normally can serve up to two terms, a term being the interval between GMs, and then need to be re-elected. Due to COVID restrictions in place during 2020, this period was extended to four years so this year those who were elected in 2018

Brian G8GQS, Dave G8GKQ, Phil M0DNY, Frank M0AEU and Clive G3GJA, will need to stand for re-election and Tony G3UIS will also need to stand for election following his co-opting on to the committee during 2023; all other members are prepared to serve another term.



Tim G4WIM has requested to step down from the committee. Noel G8GTZ, Martin G4FKK and Ian G8XZD can continue without re-election. If you fancy serving the club and would like to stand for election, please let us know 60 days before the meeting and you will need to be proposed and seconded by two other members.

Who chooses the officers?

After the GM, the new committee elects the chairman, secretary and treasurer.

Can I get an item discussed at the meeting?

Yes, but as this is a formal meeting for important club business, you must send it to the secretary 60 days before the meeting and it needs to have the support of at least 20 members of the club.

When is the meeting agenda published?

The meeting agenda is published 28 days before the meeting and will be sent to all members by email.

Can I get a vote even if I'm not there?

Yes, once the agenda has been published you can download or apply for a postal voting form – you should then return the form by post to the secretary and it will be counted as if you were there at the meeting. 🗳️



Financial report

Dave Crump G8GKQ - BATC treasurer



The BATC remains in a healthy financial state and the accounts show a surplus of £529 for 2023. However, this is slightly misleading, as I have changed the way that I estimate our liabilities to the members to better align with the way that it is defined in the constitution.

Without this change, we would have had a deficit over the year of £435. This is a small deficit (less than 1% of our assets), and reflects the intentions of our past two chairmen, which has been to spend some of the funds on promoting ATV in preference to the funds sitting in a bank account.

It has been a year of change as we opened a Lloyds current account and closed the previous HSBC current account. We have also started accepting credit card payments at rallies using a Zettle card reader. I have adopted a lighter touch approach to the accounts now that we can get electronic reports of each and every PayPal and current account transaction to provide an audit trail. This approach was approved by the committee in July.

Major expenditure in 2023 has included representation at the main Dutch Radio Rally and the purchase of a gazebo for use at UK radio rallies. Equipment expenditure has included a concept demonstration rig for a future ISS ATV/ data transmitter, a rack-mount receiver for installation at Goonhilly to receive the existing ISS HamTV transmitter and the funding of a number of ATV repeater upgrades through the bursary scheme.

None of these purchases are logged as assets, as it would be difficult to recoup any of the expenditure by sale of the goods. The items held by the club are tracked and, as an example, the proceeds from the sale of some very old (seven-year+) streaming equipment are reflected in the total donations figure in this year's accounts.

The accounts are dominated by the deposit that was paid for a new stock of tuners that should hopefully allow digital ATV to thrive during the next five-10 years. The accounts do not reflect the fact that at the end of year we also had liabilities to pay the balance of the cost for the tuners and their import duty. I have not included these liabilities as it would over-complicate the accounts and will be fully reflected in the 2024 accounts.

The income from subscriptions covers our major operating costs which are online presence and CQ-TV distribution, and leaves sufficient funds for rally attendance and bursaries. I do not see the need for any change to the subscription fees in 2024.

We have sufficient funds to continue to accept bursary requests for projects that benefit the ATV community; ATV repeater new builds and equipment upgrades would be looked upon particularly favourably.

Lastly, thanks to Tony G3UIS who has examined the accounts and made some very helpful suggestions. 🗨️

Report to the Committee of the British Amateur Television Club on the accounts for the period ending December 2023

The Committee will recall that earlier in 2023, I volunteered to be the Auditor for the Club's accounts. Following my appointment to the Committee in August 2023, it was agreed that I should still audit these accounts having only been on the Committee for 40% of the financial year. However, an alternative auditor would need to be found for the next trading year.

The Committee will be aware that generally there are a large number of relatively small transactions, with the exception of the extraordinary item of the purchase of the "Tuner" stock. The Club's Treasurer, Dave, presented me with an excellent record of the year's activities, together with statements for Lloyds and HSBC accounts. Also, was a full "PayPal" transaction list and the building society balance.

I have therefore been able to verify the opening and closing balances with those recorded in the Club accounts. With regard to the transactions, there is in excess of 350 before we count member subscriptions. I have therefore adopted a test methodology, where I have traced 35 transactions from beginning to end, spread over the 12 month period. It would seem reasonable therefore, to accept as these were perfectly clean and recorded, that other transactions would be similarly clean.

I have also reviewed the Profit and Loss and Balance Sheets for both the Committee and the Membership, and the Financial Report of the Treasurer.

It is therefore my view that the accounts, reports, and narrative represent a clear and concise statement of the Club's finances, and credit should be given to the Treasurer for the quality and detail of the work. 🗨️

ANTHONY P STONE (G3UIS), 10 February 2024

BATC Accounts as at 31 December 2023

Income Account	2021	2022	Expend Account	2021	2022
Subscriptions	£15,929.68	£15,717.84	CQ-TV Printing	£4,762.00	£3,717.20
Shop Surplus	£4,966.92	£2,921.60	CQ-TV Postage	£4,121.48	£3,602.27
Interest Received	£120.79	£293.67	Office Expenses	£151.71	£1,555.55
Donations Received	£127.00	£153.95	Committee Meetings	£130.11	£174.28
Miscellaneous	£0.00	£21.00	Members' Services	£2,065.24	£2,812.65
			RSGB Affiliation Fee	£52.00	£52.00
			Convention and BGM	£313.59	£250.00
Less PayPal Fees	-£1,933.24	-£1,319.71	Awards and Prizes	£100.00	£388.56
			Web Services	£3,216.29	£3,962.01
Totals	£19,211.15	£17,788.35		£14,912.42	£16,514.52

Income	2023	Expenditure	2023
Subscriptions	£16,897.00	Shop Postal Expenses	-£1,656.41
Shop Revenue	£13,781.82	Shop Stock Purchase	-£5,287.60
Donations	£105.73	Shop Administration	-£331.86
Forex Excess	£9.20	PayPal fees	-£1,430.10
Interest	£790.11	Zettle Fees	-£8.23
		Forex Fees	-£76.67
		Online Presence	-£4,150.49
		MailChimp	-£798.22
		CQ-TV Print	-£5,008.60
		CQ-TV Postage	-£4,669.69
		CAT Expenses	-£333.38
		Rally Expenses	-£2,480.29
		Bursary Expenditure	-£467.41
		Shop Refunds	-£64.00
		Membership Refunds	£0.00
		Awards and Prizes	-£299.59
		RSGB Affiliation	-£52.00
		Accounting Expenses	-£98.40
		Project Development	-£631.41
		Committee Admin	-£20.25
		Tuner Deposit	-£21,164.26
Totals	£31,583.86		-£49,028.86

Assets	2021	2022	2023
Shop Stock	£4,188.70	£7,605.09	£3,450.77
Current Account	£19,613.98	£8,834.72	£3,390.90
PayPal Account	£11,419.52	£15,923.31	£3,114.83
Teachers BS	£48,437.42	£48,731.09	£49,521.20
Maint Paid in Advance	£562.50	£562.50	£562.50
Serit Tuner Deposit			£21,164.26
Liabilities			
Late Payments	-£2,178.40	£0.00	£0.00
Subs Liability	-£16,134.46	-£14,473.62	-£13,492.00
Balance	£65,909.26	£67,183.09	£67,712.46
Balance brought forward	£61,610.53	£65,909.26	£67,183.09
Surplus or Deficit	£4,298.73	£1,273.83	£529.37





Introducing the PicoTuner

<https://wiki.batc.org.uk/PicoTuner>

Dave Crump G8GKQ

The MiniTioner has been the go-to device for receiving digital ATV for the past eight years. It uses an FTDI module for the USB interface which has been gradually increasing in cost over the years to its current price of around £32.

When it was realised that the new batch of Serit tuners were going to cost significantly more than previously, renewed effort was put into finding a cheaper alternative to the FTDI module.

Colin G4EML volunteered to attempt to program a Raspberry Pi Pico to do the job. The Pico is a cheap capable microcontroller module based on the RP2040 microcontroller chip designed by the Raspberry Pi team.

The basic Pico (without wireless) comes in two versions, one with header pins (the Pico H) at about £5, and one without header pins (the Pico) at about £4.

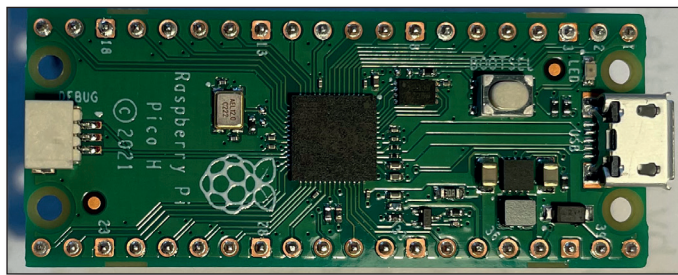

► The Raspberry Pi Pico H

As can be seen from the photo, the Pico has plenty of input/output connections and a USB socket.

Over the past two months, Colin has developed the software required for the Pico, helped by a team of beta testers who have been discovering bugs and providing Colin with enough information to fix them.

On each occasion, improved versions have been released for testing. At the time of writing, the 10th version had just been released for beta testing with just one, known and very difficult to reproduce, bug.

The PicoTuner transfers data to the host computer differently to the MiniTioner and is able to control and send out the pictures from both tuner channels in the Serit FTS-4334.

This enables Tom, ZR6TG's OpenTuner software to display two signals at once which is particularly useful on QO-100.

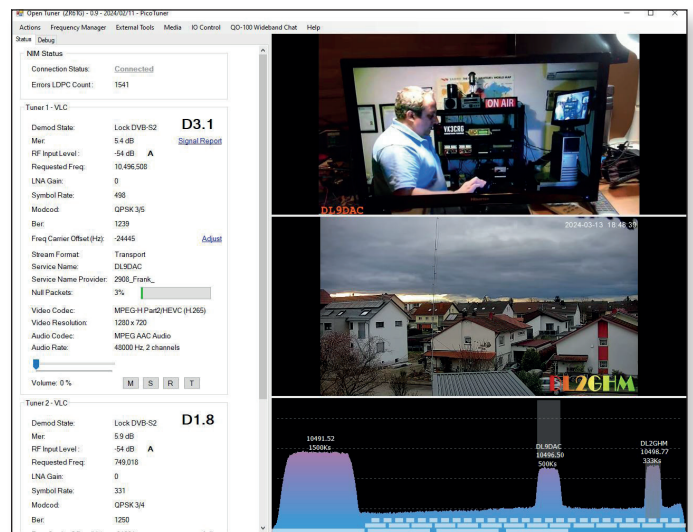

► OpenTuner displaying two transport streams from one PicoTuner

The Portsdown is only able to display one signal; the same limitation will apply to the Ryde once it has been modified to work with the PicoTuner.

Putting together a PicoTuner

The name “PicoTuner” describes an assembly with a Serit FTS-4334 tuner and a Raspberry Pi Pico USB interface running G4EML's software.

It will also include some power supply circuitry and possibly some LNB voltage supply circuitry. There are two options to achieve this, either an adapter module that plugs into the existing FTDI socket, or a complete new PCB design.

The adapter board is already available in the BATC shop and is described elsewhere in this issue; the new PicoTuner PCB design is being finalised and will be available soon.

Note that the USB socket on the Pico is a USB micro, not a USB mini as used on the FTDI module. The new PicoTuner PCB will have pads to mount a mechanically robust USB type B socket on it.

Programming the Pico

The BATC will not be selling programmed Picos; the blank module is available very cheaply from Raspberry Pi suppliers and are very easy to program:

1. Download the latest release of the Pico software from Colin's GitHub site:
<https://github.com/g4eml/PicoTuner/releases>
The filename will be of the form "PicoTunerVx-xx.uf2". There is no need to download any of the source code.
2. Press the white "Bootsel" button on the PCB while connecting the Pico to the computer's USB socket (needs two hands).
3. Once you hear the "bing-bong" on the computer indicating that a new storage device has been attached, release the button.
4. Open Windows Explorer and look for the "RPIRP2" storage drive.
5. Drag the downloaded PicoTunerVx-xx.uf2 into the RPIRP2 storage drive to copy it onto the drive.
6. When the copy is complete, you will hear a drive disconnecting "bing-bong" and the RPIRP2 drive will disappear.

The Pico is now programmed.

PicoTuner-compatible receive software

The new PicoTuner is not directly compatible with the old FTDI-based MiniTiouner. Although it still uses USB, the internal structure is different and video data is transferred in a different format.

This means that, where possible, existing receive software needs to be modified for compatibility. The table below summarises the situation as at mid-March 2024.

Tom's OpenTuner fully exploits the PicoTuner and can display the signals from two frequencies at once. You can find full details, and download the latest version from his web page here: <https://www.zr6tg.co.za/open-tuner/>.

Installation is easy. Download the (large) file, create a new folder and unzip the file into that folder. Double click on the "opentuner" or opentuner.exe program to run it.

Note that after starting OpenTuner for the first time, you will need to go into actions, settings and set the default interface to PicoTuner. You might also need to adjust your LNB offset on this page.

Each time you start OpenTuner you will need to click the red "Disconnected" at the top left of the window to connect to the PicoTuner.

The latest version of Portsdown 4 will work with OpenTuner in exactly the same way as MiniTiouner, and this support will be extended to the Portsdown 2020 once testing is completed. No special configuration of the Portsdown is required. Modification of the Ryde software to work with PicoTuner is under way.

Should the message "waiting for tuner to respond" be displayed for more than a few seconds on Portsdown, disconnect and reconnect the PicoTuner USB lead and then reselect receive. This bug is under investigation.

Thanks to Colin G4EML for his excellent work on this project, and to his team of helpers (too numerous to list) for their assistance. A true community project. 🗨️

A new PCB for the PicoTuner

Development of a new PCB for the PicoTuner is well underway. Following the build of the first beta version, pictured below, a second version has been ordered and should be available in the BATC shop soon assuming that testing goes OK. 🗨️

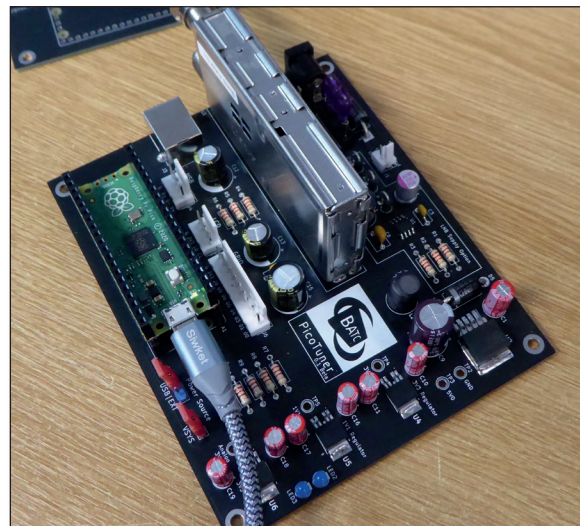

Software	Platform	MiniTiouner?	PicoTuner?	Notes
MiniTioune	Windows PC	Yes	No	Unlikely to be updated
Portsdown 4	Raspberry Pi 4	Yes	Yes	
Portsdown 2020	Raspberry Pi 3	Yes	Not yet, but planned	
Ryde	Raspberry Pi 4	Yes	Not yet, but planned	
OpenTuner V0.9	Windows PC	Yes	Yes	Two frequencies at once
DATV Red Integrated RX	Windows PC	Yes	No	

BATC shop EU warehouse

Noel Matthews G8GTZ

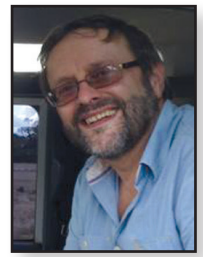

Great news for our European members.

Benno PA3FBX has volunteered to run a BATC shop warehouse in the Netherlands which will ship all orders to our members in the European Economic Union.

This means there will be no customs clearance required for these orders and it will reduce the shipping time, sometimes by several weeks, and members will not have to pay any customs duty when they receive their orders.

Nothing will change when you place an order in the shop and you will still pay via Paypal or bank transfer to the BATC in the UK. After that, the system will decide if your order should be shipped from the UK or from the Netherlands.

Benno will hold most items in stock but occasionally some items will be shipped from the UK and may be liable to customs duty before they are delivered.

Orders for the UK and the rest of the world will still be shipped from the UK and those shipped to outside the UK will still require customs clearance.

Benno can be contacted at eshop@batc.tv Please use this email for any BATC EU shop queries and not his personal email address. 📧



Surface mount Pico adaptor for the MiniTioner V2 PCB

Dave Crump G8GKQ



While the PicoTuner interface was designed for use in a new tuner design it can also be retrofitted to the BATC V2 MiniTioner and similar designs.

This involves removing the FTDI module, replacing it with an adaptor pcb and adding five wires to connect signals that are not present on the FTDI sockets. The advantage of doing this upgrade is to provide access to the second transport stream.

When supported by the host software this then allows the reception of two signals at the same time.

To save space and to try to make the module mechanically compatible surface mount techniques are used. However due to the large size of the components involved it is still easily assembled by hand.

Full assembly details and the bill of material are available on the BATC wiki https://wiki.batc.org.uk/PicoTuner#Surface_mount_Pico_adaptor_for_the_Min iTioner_V2_PCB 📧

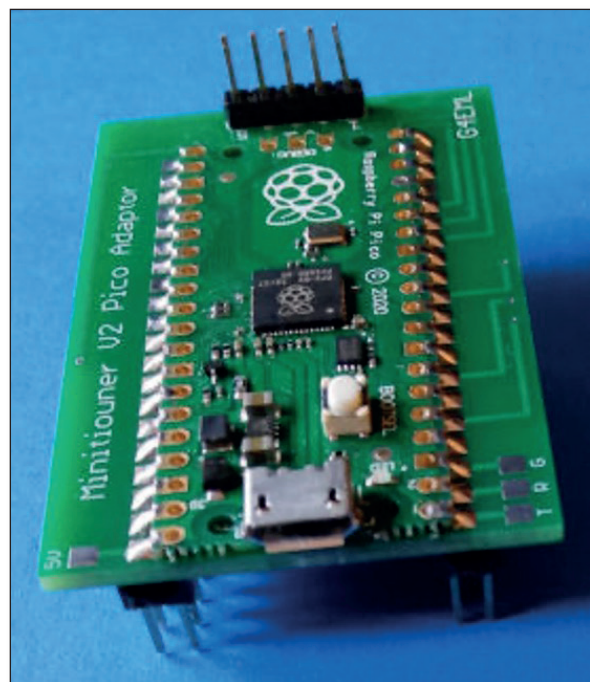



Going digital with two triple Ryde receivers

Wilko PAI WBU, Stichting STTA

Introduction

In Arnhem, in the eastern part of the Netherlands, the ATV repeater with the callsign PI6ANH lives on the 18th floor of a free-standing concrete radio transmission tower, about 125m above NAP (Dutch reference level).



► The tower

Locally this tower is known as the “KEMA tower”, although in fact it was never owned by KEMA. Rather, the tower was originally built for the SEP, the maintainer of the Dutch national power grid (now: TenneT).

Its purpose was to house microwave telemetry transmitters/receivers used for controlling the national grid. It is no longer in use for that particular purpose. Currently it is being used for an interesting collection of both analog FM and DAB+ broadcast transmitters, a Tetra node for the Entropia company, various microwave links for telecom operators etc. And it houses PI6ANH, obviously the more important infrastructure in the scope of this article.

PI6ANH history & setup

PI6ANH has been around for at least 25 years (i.e. far longer than yours truly holds a callsign) and has been located at various sites before arriving on the tower. All in all it occupies no less than three 42U-high 19” racks.

► Receivers, A/V matrix to the left and control PC etc to the right



► Power amplifier and coax rack

PI6ANH transmits analog ATV in the 13cm band, as per Dutch licenced shared access rules, at 2387 MHz to be exact. It does so using three sector slot aerials, (roughly) covering an easterly, southerly & westerly sector.

There are no aerials pointing north, for the simple reason that the view to the north is quite obstructed by the high grounds of the Veluwe (i.e. the Netherlands are not as flat as some would like you to believe).

At each of the east, south and west sectors it has rx aerials for 70 cm, 23 cm, 6 cm and 3 cm ATV receivers are installed for analogue as well as in a (RB) DATV.

Obviously it has audio and video matrices (Kramer in our case), a repeater controller, power supplies, bias-Ts, coax splitters, remote power controllers, filters, combiners, splitters, circulators, network gear, a PC and whatnot. Interconnecting all of the aerials is a truly impressive cable plant, using coax cables with diameters equivalent to vacuum cleaner hoses. Like Pascal PAI PAS once told me “wait till you see PI6ANH, voice repeaters are boringly simple”. Prophetic words.

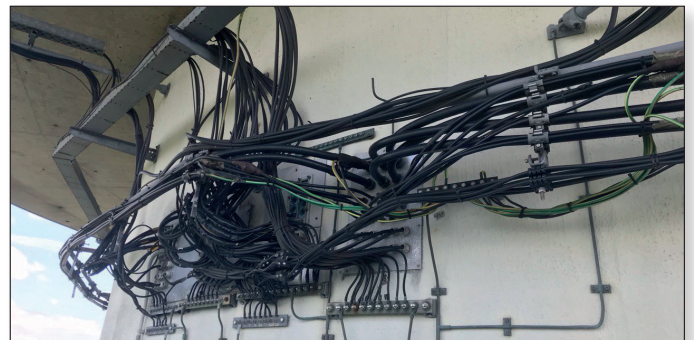

► A bit of coax. Granted, some of it is part of a telco installation.



► Facing east towards John Frost Bridge, 3 cm slot aerial to the right, 70 cm aerial bottom and round camera ‘ball’ to the left.

There is also quite a bit of miscellaneous equipment for non-ATV housed in the racks, e.g. for HAMnet, rx for the STTA 23 cm and 70 cm voice repeaters, rx for 70 cm LoRa APRS, tinyGS LoRa and so forth.

Evolution: maintenance and (more and more) digital

A couple of years back the original builders & maintainers of PI6ANH for various reasons expressed a desire to scale down their involvement and hand over their hard work to the next generation. For advice and assistance they remain available, a big thanks for that of course.

We stand on the shoulders of giants as the proverb goes. At that point in time the STTA foundation arrived at the scene. The STTA essentially comprises of three people, Pascal PA1PAS, Roel PE2CVF and yours truly, Wilko, PA1WBU.

A lot of discussion and extensive head scratching led us onto a path to modernise PI6ANH in multiple ways and step by step. These changes in summary involve: lots of maintenance of equipment and aerials, getting rid of the power hungry Barco DVB-S receivers, replace the original home-built A/V matrix which started to show its age due to component wear-out, replace the repeater controller based on a PC by a more power-efficient Raspberry Pi that as a bonus can also handle DTMF for remote repeater control, add an internet stream to Twitch and lots more. Until further notice transmission is to remain analogue.

Digital receivers it shall have

As said, the Barco rx had to go. Not only because of kWh reasons but also because we wanted to accommodate RB-DATV, on 23 cm as well as on 70 cm. Allowing the use of 70 cm means that the Dutch novice amateurs can make use of PI6ANH, for example using a ADALM Pluto and a power amplifier.

These requirements made the short list an extremely short one: the Ryde receiver would be the weapon of choice.

The fact that we no longer wanted to use coax relays for connecting a particular rx to a particular aerial (under control of the repeater controller) lead to the “one Ryde per aerial” approach. Which in turn, given both 23 and 70 cm were desired in any simultaneous combination for each of east, south and west, meant we needed no less than six Ryde receivers, so six Minitouners plus six RaspberryPi 4.

Plus six HDMI – AV translators (more on these later). In short: a brute force approach, at the expensive of a

considerable amount of Euros. For 3 cm (e.g. the dedicated rx for PI6ATV) we use Octagon satellite receivers. The Octagons have proven susceptible to firmware lockups when confronted with a random barrage of DATV signals. Ryde receivers appear immune in this respect.

The build of the Triple Ryde Mk I

After the basic design was decided on, we duly proceeded to acquire all the parts, like Minitouners (from the REF in case of the Mk I), Raspberry 4s, microSD cards etc. As nature had it, the whole project coincided with the Covid-19 pandemic. Meaning supply chains going haywire, everything in short supply (with the notable exception of theories on viruses and vaccines) etc etc.

Long story short: we got the parts together and yours truly took on the job of fitting all the bits and bobs into a 2U high rack tray. That turned out to be a very interesting exercise indeed: it did fit in the end. But barely.

The near death experience as far as “will it fit or not” occurred when Pascal PA1PAS belatedly arrived with three HDMI – AV translators and the remark “Oh, by the way these need to go in as well.”

At that time I promised myself I would never ever again start a build before I had all parts available. In any case the picture below speaks for itself. It did fit, and it proves to work reliable 24x7. I consider it my magnum opus as far as building things goes (and I have built a lot of things over the years).

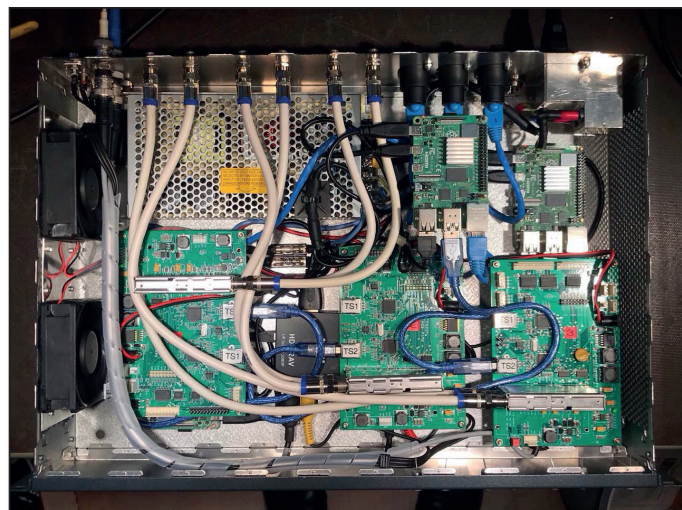

► Above: Mk I top view

► Below: Mk I, front view

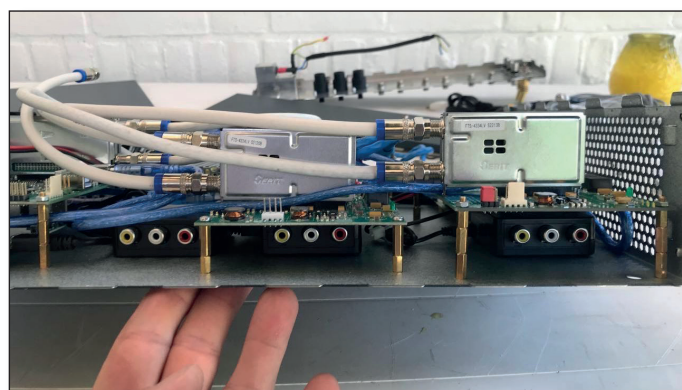

The Triple Ryde Mk2

As we all know, we (should) learn from our experiences. A 2U 19" rack tray had proven to be slightly ambitious for a triple Ryde config. So a surplus 4U rack tray was duly repurposed. A 3U tray would have been sufficient but this one was at hand, no extra expense was required which made the decision an easy one.

Some surplus Mikrotik GbE ethernet switches had also arrived, so it was decided that the Mk2 would have one of these fitted. This to allow a single GbE uplink of the Mk2 to the network, instead of three separate GbE links, one for each RaspberryPi, that the Mk1 used.

Fewer cables, always nice given the cable mess that a ATV repeater tends to become. The BNC connectors on the back panel are of the Neutrik form factor. This allows the easy replacement of the BNC connectors by HDMI connectors (also in Neutrik form factor) once we move to a digital video stream.

The HDMI – AV boxes can simply be removed, the BNC connectors swapped for HDMI and all that without having to drill different holes. Minitioners for Mk2 were acquired from the DARC. RaspberryPi had become sort-of available again for normal prices. Long story short: the picture of the Mk2 says more than a thousand words. It is obviously more spacious in there. Mk2 so far has proven to be just as stable as Mk1.



▶ Mk2 in test

Future ideas and plans

Running a ATV repeater is both a time consuming as well as a rather expensive undertaking. We still need to do more maintenance, e.g. on some of the slot aerials, the racks need new cooling fans fitted, a HAMnet WiFi link needs to be replaced and so on.

Longer term there are ambitions to (also?) transmit DATV. Or maybe make analogue/digital transmit selectable via the repeater controller. Or maybe simultaneous analogue and digital transmission can be shoe-horned into the allocated bandwidth? For now going digital for tx is not on the near horizon.

So much work, so little time. 🗨️

Links

- ▶ The PI6ANH signal is viewable via the internet using Twitch, at <https://www.twitch.tv/pi6anh>
- ▶ The STTA website can be found at <https://www.pi4tta.nl>
- ▶ A very nice drone video of the tower can be found on Youtube (PI6ANH is on the floor just below the glass enclosed ring) <https://www.youtube.com/watch?v=3Jcpz8jjbMA>

On behalf of the STTA team,
73, Wilko PA1WBU
PA1WBU@xs4all.nl

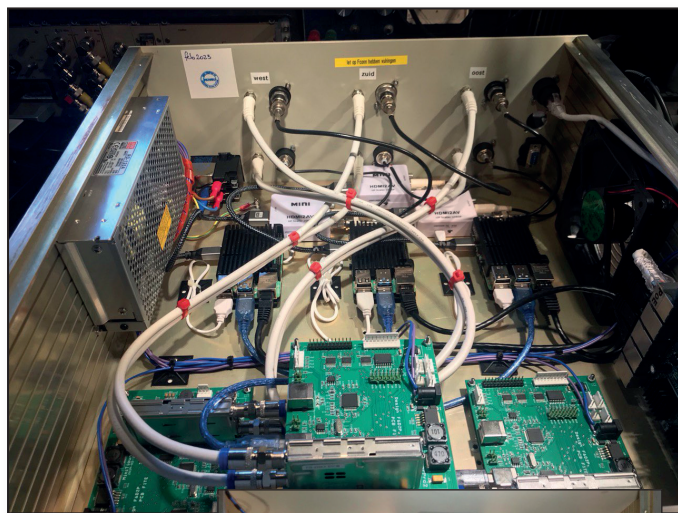

▶ Mk2, front view

▶ Mk2, top view

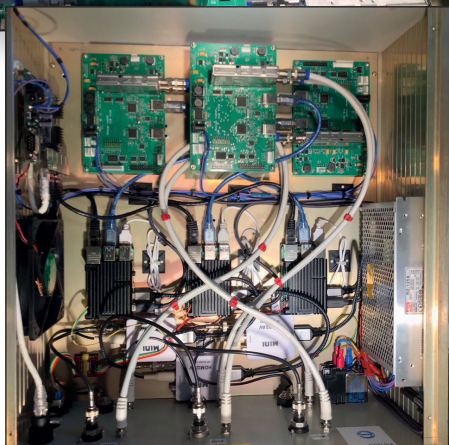



Cheap video cameras with poor colour reproduction

Chris van den Berg PA3CRX

Have you ever bought such a cheap CCTV camera, or are you planning to do so? The image quality may be somewhat disappointing.

That's because they are also intended to be used with infrared light. The object to be viewed is illuminated by a number of infrared LEDs and the camera must of course be able to see that IR light.



► My cheap IR camera, it contains even a microphone (the clamp is a clothespin)

This is useful if you want to view something in the dark like roving in the evening.

If it is just daylight, the colours are pale and do not relate correctly to each other.

However, this can easily be solved by adding an IR filter. Such an IR filter looks like a very light green/ turquoise glass.

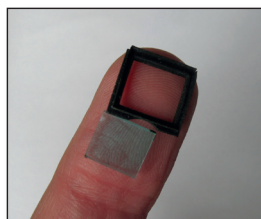

► IR filter glass with frame, cannibalised from a defective 8mm video camera

If the IR filter glass is held in front of the lens, the improvement can be seen immediately.

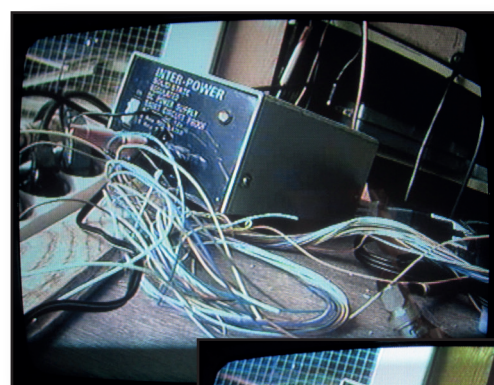

► Picture of the CRT monitor, showing camera image without IR filter, daylight

► Same picture but now with the IR filter in front of the camera lens

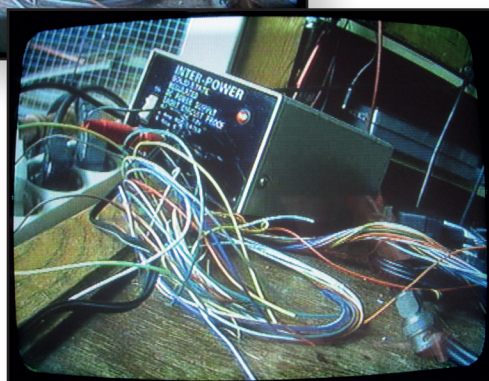

So it can be attached in front of the lens with some glue on the edges. If there is space it can also be placed inside the camera; at the back of the lens or directly on the CCD.

Getting such IR filter is not difficult.

Once I dismantled a defective 8mm video camera and found the IR filter glass in front of the CCD.

It can also be taken from a digital photo camera.

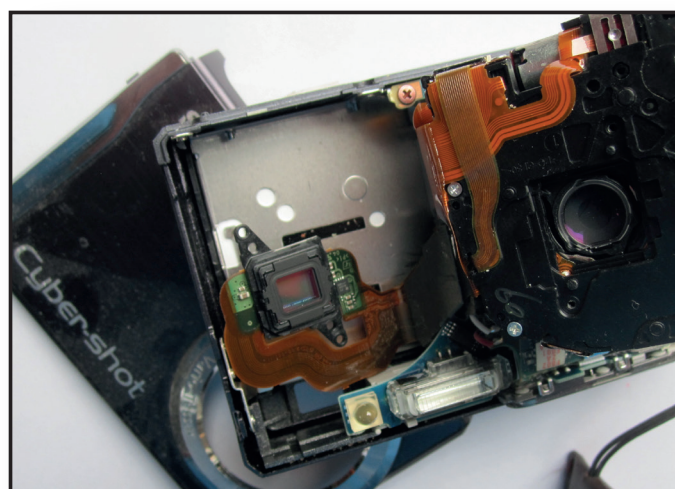

► IR filter inside the defective photo camera, with a small rubber frame directly on the CCD

Or in case you order the IR camera on the internet, an IR filter glass could be ordered at the same time. I saw very cheap round and rectangular ones in various sizes offered by the known Chinese web stores.

The disadvantage of adding the IR filter is that you could no longer see in the dark with the IR LEDs. Since the LEDs have now lost their function, they could be disconnected from the power source to reduce energy consumption, especially welcome in case of a roving station.

Such cheap camera could be kept with the roving station so you never will be in the field finding out you forgot a video source. 🗨️

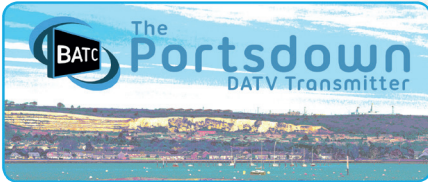

The Portsdown Newsletter

Dave Crump, G8GKQ

Incremental improvement and bug-fixing of Portsdown 4 capabilities has continued over the past three months; one of these improvements has been relevant to the Portsdown 2020 and so has been included in a recent update.

PicoTuner support

The Longmynd-based receiver in the Portsdown 4 has been modified to support the PicoTuner. Operation using PicoTuner is almost identical to that using MiniTioner - a testament to the excellent work of Colin G4EML in programming the Pico. Once final tests on the Portsdown 4 are complete, the Portsdown 2020 will also be modified to support PicoTuner.

Network search tools

One of the problems when adding new Raspberry Pi based devices to the network is finding their IP address when they are first connected. Tools like Advanced IP Scanner (PC) and Fing (iPhone) help, but given that I almost always have a Portsdown 4 powered up in the shack, I thought that it might be easier to add some sort of network search tool to the Portsdown 4. This proved reasonably easy.

On the file menu (selected from menu two), there are two new buttons: "List network Raspberry Pis" and "List network devices".

List network devices lists all the devices on the LAN, but given that there always at least 20 devices on my LAN, this is not as easy to use as it might be to find Raspberry Pis.

List network Raspberry Pis does exactly what it says, but some explanation might help, as additional information is presented.

► The "List network Raspberry Pis" screen

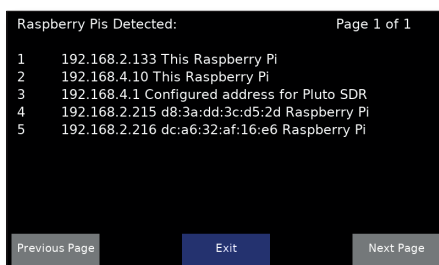

If you have a Pluto SDR connected, there can be two addresses shown for "This Raspberry Pi". One is the Pi's address on the LAN, and the other is the address it uses to communicate with a USB-connected Pluto. The application also looks up the address that you have stored for the Pluto and displays it for checking.

Note that my Pluto has been reprogrammed to use 192.168.4.1 to avoid a conflict with my home LAN which is on 192.168.2.*.

Two other Raspberry Pis are shown having been detected on the LAN at 192.168.2.215 and 192.168.2.216. You could disconnect each in turn and repeat the test to identify them if required. The "d8:3a:dd:3c:d5:2d" is the hardware MAC address of the Raspberry Pi; this does not change when it is connected to other networks.

Band switching for Pluto BandViewer

Benno PA3FBX's multiband multimode transceiver (described in CQ-TV 282) incorporates Pluto BandViewer, but there was no capability to switch the Pluto input between the various aerial inputs for each band.

I have added the capability to Pluto BandViewer (not BandViewer for other SDRs) to configure band selection in a similar way to the Portsdown transmitter. Given that this is a complex and rarely used capability, it is configured by editing a text file `/home/pi/rpidatv/src/plutoview/plutoview_bands.txt`.

The file is reasonably self-explanatory; the `bvswitchenable` line needs to be set to `on`, and then the low and high limits for each band can be edited. The defaults are the same as the defaults for the Portsdown transmitter.

```

bvswitchenable=off
bvband0lo=60.0
bvband0hi=100.0
bvband1lo=100.0
bvband1hi=250.0
bvband2lo=250.0
bvband2hi=950.0
bvband3lo=950.0
bvband3hi=2000.0
bvband4lo=2000.0
bvband4hi=3000.0
.
.
bvband13lo=0.0
bvband13hi=0.0
bvband14lo=30.0
bvband14hi=60.0
bvband15lo=3000.0
bvband15hi=6000.0
premix1low=0.0
premix1ohi=0.0

```

Benno uses a DXPatrol transverter to allow reception and display of the HF bands, so I also added the facility

to enter two pre-mix local oscillator frequencies. The first, `premixlow`, is added to the entered frequency to set the Pluto centre frequency if the entered frequency is below 70 MHz.

The second, `premixlohi`, is subtracted from the entered frequency to set the Pluto centre frequency of the frequency entered is above 6 GHz. This might typically be set to 9750.0 to enable direct readout of QO-100 frequencies from a standard LNB. If `premixlohi` is set

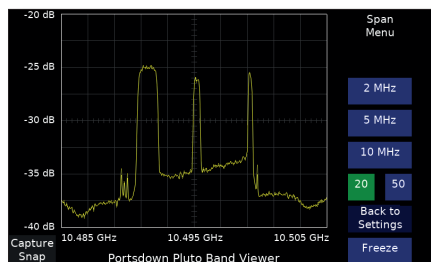

to 0.0, selection of frequencies between 6 GHz and 30 GHz invoke Pluto fifth harmonic receive mode.

▶ *BandViewer display with pre-mix calculation applied*

Once you have edited the `plutoview_bands.txt` file and saved it, you will need to restart the Pluto BandViewer to apply the changes.

Portstown 4 web control

I introduced web control to the basic Portstown system some time ago and I have been expanding this capability to other applications. Currently the following applications work with web control:

- ▶ SDRPlay BandViewer
- ▶ MeteorViewer
- ▶ RTL-SDR BandViewer
- ▶ Signal generator

Most other applications (apart from the receiver) provide a display in the web browser, but cannot be controlled by the web interface.

Portstown 4 and HDMI displays

There is no HDMI output available from a Portstown 4 when the seven-inch screen is connected; this is a hardware limitation. I was asked whether HDMI would work without a seven-inch screen connected (using web control); initial tests failed because most Portstown applications check for a touchscreen and exit if one cannot be found.

However, I have now modified some of the Portstown applications to run in "web controlled with HDMI display" mode. This uses HDMI output 0, the one nearest the USB-C power input socket. **Note that this facility does not (and will not) support HDMI touchscreens.**

By default, the HDMI output on the Portstown is set to 800x480, and this is not supported by some HDMI devices. I have added a menu to select the desired HDMI resolution, and to select a reboot to apply the change. This can be found at menu three, system config, browser, and is only available when a touchscreen is not fitted.

Note that the Portstown menu and other Portstown-generated displays (such as BandViewer) remain at 800x480 so look small in the top left-hand corner of a 1080p display; 720p is more acceptable.

The receiver, when using VLC, does play using the full screen (and full resolution) at 720p and 1080p. The next problem was audio, which was only selectable between a USB dongle and the RPi audio jack. I have added a third option to the audio button (on menu three and the receiver config page), to select HDMI.

The web-controlled HDMI display provides a good facility for web-controlled demonstrations on large-screen displays and also for viewing HD received pictures.

I will add HDMI output to other applications as and when I convert them to web control.

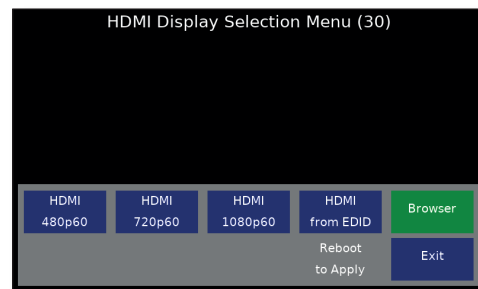

Portstown 2020 and HDMI displays

As with the Raspberry Pi 4, the HDMI output on the Raspberry Pi 3 does not work when a seven-inch touchscreen is fitted. It does, however, work when a Waveshare 3.5 inch screen is fitted. I have added the facility to route the audio to HDMI to Portstown 2020 and it does work well as a touchscreen-controlled receiver with an HDMI display. I do not expect transmit using the Portstown filter-modulator board to work; DATV Express and LimeSDR might work, but I have not tested them. Note that web control is not available on the Portstown 2020.

Support for ISS HamTV reception

The Portstown receiver will work for HamTV reception, and BandViewer can be used for helping with signal acquisition. The Portstown noise meter can be used for checking sun noise when setting up a receiving dish.

I will be working on providing extra functions to make it easier to set up a HamTV receive station using the Portstown. More news in the next CQ-TV. 📡



Impact of Amp Over-drive on DATV?

Jim Andrews, KH6HTV,

Reprinted with permission from:
Boulder Amateur Television Club - TV Repeater's
REPEATER, March, 2024

Recently one of the Boulder ATV hams posed the question --- "Why when I over-drive my amplifier don't I see a degradation in the S/N at the repeater?"

We have always preached the DTV rule that we don't want to drive our rf power amplifiers any harder than that level which creates the out of channel inter-mod spectrum growth with a shoulder break-point at -30dB below the in-band rf power level. (note: This measurement is made by first measuring the rf power at the center frequency. Then measuring the rf power on the shoulders at a point 200 kHz beyond the TV channel band-edges.)

So, this called for still yet another experiment. I set up a bench test using a Hi-Des HV-320E modulator driving a model UWB-103 broad-band amplifier (250kHz-3GHz, 20dB gain, +22dBm (sat) to various levels of saturation creating the spectrums shown above in the photo. By over-driving this amp, the out of channel, inter-mod spectrum grew very rapidly. The worst case shoulders I was able to create was with a -16dB break-point. This gave me the ability to test a DTV receiver with various levels of shoulder break-points. I then attenuated this signal by 60dB to avoid overloading the front end of the DTV receiver. I used a Hi-Des HV-110 because of it's capability to measure and display both the received signal strength in dBm and also the received signal to noise ratio in dB. There are three types of constellations available with DVB-T, namely QPSK, 16QAM, and 64QAM. The respective max. S/Ns for these are: 23dB, 26dB and 32dB. I set the modulator's digital parameters to HDMI in, H.264 encoding, 1080P resolution, 5.5 Mbps, 5/6 FEC and 1/16 Guard.

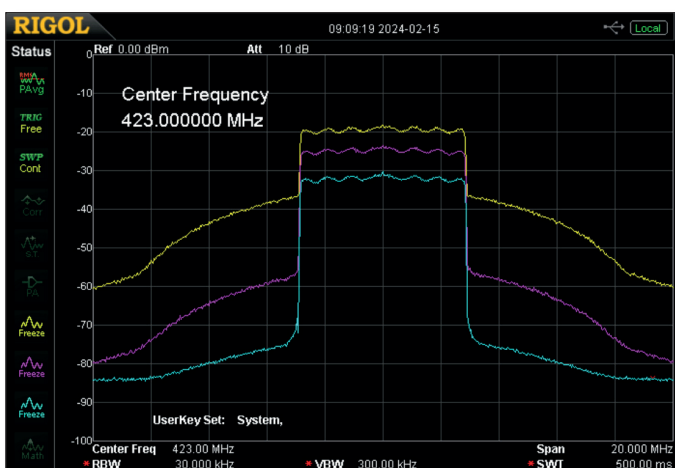

At this setting, the min. required S/N was 8dB (QPSK), 14dB (16QAM) or 21 dB (64QAM). I then tested for all three constellations.

Here are the conclusions from my over-drive tests:

QPSK – The s/n stayed at max. 23dB until the shoulder break-points dropped below -21dB. The receiver continued to decode successfully with s/n = 12dB at -16dB shoulders.

16QAM – The s/n stayed at max. 26dB until the shoulder break-points dropped below -25dB. The receiver stopped working at -17dB shoulders.

64QAM – The s/n stayed at max. 32dB until the shoulder break-points dropped below -30dB. The receiver stopped working at -23dB shoulders.

QPSK works better than QAM in much the same fashion as FM outperforms AM. QPSK being purely phase shift keying is independent of amplitude variations, is much more like FM. QAM adds amplitude modulation on top of phase shift keying and thus starts to suffer the well known limitations of AM.

So why should we stop at -30dB shoulders? As hams we always are wanting to put out the absolute most RF power possible. At -30dB shoulders, we have an acceptable compromise between putting out a strong, in channel signal and keeping to a minimum our pollution of the spectrum in the adjacent TV channels. Plus, as we saw above, if we were using 64QAM, we would start to degrade the quality of the DTV signal if the shoulders got any worse than -30dB. 🗨️

Feedback on the original article:

On page 2 you state "QPSK being purely phase shift keying is independent of amplitude variations, is much more like FM!". I do not believe this to be true and if you look at the trajectories on the Real/Imaginary constellation they are not constant amplitude and the diagonals actually go through 0. The improved performance comes from the decreased theoretical carrier to noise requirement for QPSK (15dB) vs. 16QAM (22.5dB) and 64QAM (28.5dB).

Another way to look at it is from the point of error vector magnitude (EVM) tolerance. Since the QPSK states exist within a bigger "box" they can allow for much higher levels of noise and distortion before the EVM indicates an error.

Steve, WA0TQG

Portable DATV at GX3WIM/P

Gareth, G4XAT



Every year the Wimbledon and District Amateur Radio Club runs a week-long field-based activity, usually in a farmer's field atop Reigate Hill (Surrey Hills), generally starting on the last Saturday in July and running the full seven days.

Over the years I have attended for occasional days, finally organising myself to take Mr Whippy (camper/radio truck) for two extended activities in 2019. I soon found that with the main station GX3WIM/P running 400 watts on HF rendered using the other HF bands 'challenging'.

Covid curtailed activities but this year (2023) I'd cleared the domestic calendar (itself a tricky task) and arrived on the first Saturday morning to help put up the HF station. The experience of John, G8MNY makes for successful events (well he has been doing /P since the 1970's) and everything was assembled and the mast was soon up (gin pole assisted).

The three-element tribander was fitted, then a 6m yagi and a three-band white stick co-linear completed the mast load. With that checked and tied off, dipoles for 40 & 80m were hung from well-placed trees by catapult or 'lead-swinging'.

A long-wire was used for 160m. With most of the labour done, I returned home to load up with stuff for /P operation via QO-100. As the next day was a microwave contest, I put the 65cm dish and a 'Tilt-O-Matic' in along with my mast, 70cms beam, 24cms double bi-quad and attendant gear.

10GHz was set up quickly, but nearly all directions were foliage-attenuated and no contacts were made. Using DATV, 70cms and 50 watts got me into GB3JV (Petts Wood) at good strength despite a wall of trees but 23cms even with 100 watts couldn't raise a 'K'.

Swinging round to GB3EN (clear path past the trees) got a good report. Progressing to QO-100, the dish was quickly aligned using a Lidl angle finder and a spirit level to set recorded elevation and a compass for azimuth.

Careful searching with my tweak-master CCTV head and using the excellent MER-meter capability of Portsdown 4 soon had a MER of 9.5, not bad for a 1.0 x 1.1 m dish.

Tx followed and a DC input of 200W provided a good signal in. There followed various demos and descriptions of what was going on to fellow amateurs. The weather (as we now know the wettest July ever) lived up to its name and rain set in, curtailing much more activity.

Working under the car tailgate kept the equipment and myself dry, until I closed the tailgate where the small lake that had gathered in the number-plate recess was deposited at my feet.



Having proven the portable QO-100 capability, I planned to join in the Thursday evening BATC net from the same venue. Thursday was promised dry and other than a late call from Martin G4FKK asking me to run the net all was looking good.

I arrived on site around 5pm and was up and running by about 5:45. My little Suzuki 110V 500W generator was started (a £15 boot fair find) and used to supply my laptop charger and LiPO4 battery charger (a slightly tweaked HP Server PSU) as both these are rated for 110-240V input.

That worked well although not really needed, neither was the four-panel Solar system I was recently donated. In full sun, this puts up to seven amps into the battery.

Consumption of everything running for the whole session was just over 40AmpHr. The system comprised my main Portsdown 4 with C920 webcam and external AGC mic, driving the built-in Pluto set at -18dB then into a filtered Amsat pre-driver which drives a UMTS capable of 150W (if needed). 4m of LDF4-50 feeds a POTY on the TRIAX 1.0x1.1m dish, mounted upside down to reduce windage.

My laptop was hot-spotted via my phone for accessing the wideband chat monitor and a second Portsdown hosted a RTL dongle showing the top 2MHz of the band. This was useful to spot when carriers were dropped. Live reception was via a Ryde and monitor/speaker.



The net went well without any glitches and I was able to wind things up around 9:20pm. With everything packed away a 30 minute journey home completed a successful outing, nothing forgotten, nothing failed. That's a first :-)

As the gear was already in my car, I took it along to my club night and set up in the car park. As the photo shows I had a good line to the satellite past the church hall and once again the set-up was demonstrated to club members. (Surrey Radio Contact Club). 🗨️



Poor man's bandviewer

Many people, including myself, bought one of the very cheap Quansheng UV-K5(8) dual band radios (the version with the orange screen) a while back.

It is a well-built 2m/70cm handheld which, while not in the league of Icom or Yaesu radios, does give a reasonable account of itself - but hey you get what you pay for

Part of the attraction - other than its £10 cost including delivery - is that it is very easy to install new firmware on it by simply using the Chrome browser and a Baofeng UV-5R programming lead.

Probably the most useful version of firmware is one from EGZUMER and available here:

<https://github.com/egzumer/uv-k5-firmware-custom/releases>

The update from browser detailed on the GitHub page makes the whole process easy - though obviously you are trashing any guarantee on the radio and are doing it at your own risk.

Of particular interest is the spectrum analyser option by first pressing F on the radio's keyboard then five

It comes up on the centre frequency you've set on the active VFO - you can change the parameters of the scan from the radio keyboard (see instructions on link

<https://github.com/egzumer/uv-k5-firmware-custom/wiki/Spectrum-analyzer>

With the right settings it is reasonably sensitive to a DATV signal on 2mtr or 70cm. With the enhanced software the radio will also cover 10m, 50MHz, 70MHz and part of 23cm - though obviously the sensitivity won't be as good out of spec and you may find other unwanted artifacts on hill tops.

It's all a bit of fun rather than quality software like the Portsdown band viewer but it might help you find that little bit of DX from the shack. 🗨️

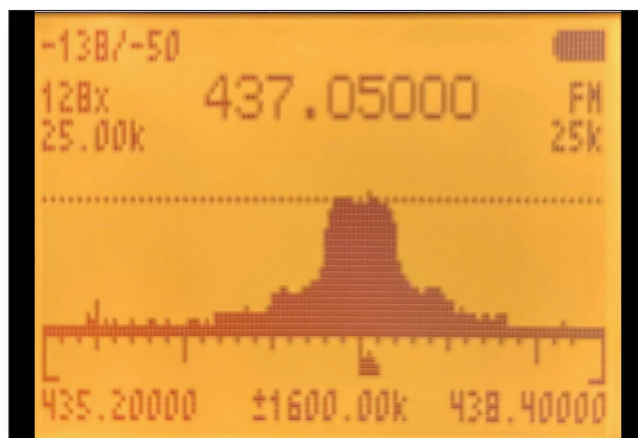



The Portsdown noise meter

Dave Crump, G8GKQ

The Portsdown test equipment suite has for some time included a noise figure meter that operates with a LimeSDR to measure the difference between received noise with a noise source on and a noise source off.

It uses these measurements to calculate and indicate equipment noise figure. However, there has been no capability to measure and indicate a slowly varying noise level across a band of frequencies, or to compare the noise level between two bands of frequencies.

Measurement and indication of noise level is very useful when checking microwave dish efficiency or alignment, as it allows sun (or moon) noise to be quantified and recorded.

Intended capability

The Portsdown 4 noise level meter uses a LimeSDR Mini to measure and indicate noise or carrier power levels. It has four modes:

- ▶ Absolute noise measurement
- ▶ Differential noise measurement
- ▶ Carrier level over noise measurement
- ▶ Absolute carrier level measurement

Absolute noise measurement is used to measure sun or moon noise. The system can be “zeroed” against cold sky, and then the meter will indicate the increase in noise averaged over a wide bandwidth.

Differential noise measurement can be used to measure the strength of DATV transmissions or possibly to optimise aerial/receiver matching. The noise power in a reference (quiet) frequency range is measured and compared with the noise power in a frequency range that contains a DATV signal. Finally, the carrier level measurement compares the peak level of a carrier within a defined frequency range with the average noise level in a quiet frequency range.

The noise level meter is selected from Menu two, test equipment. Web view (but not web control) is implemented for the noise level meter. The noise level meter is only included in the Portsdown 4 (not Portsdown 2020) and only works with the LimeSDR Mini (V1 or V2). The desired mode is selected using the “mode” button on the noise meter menu.

Absolute noise measurement

On starting the meter, use the “freq and bandwidth” button to select the frequency and bandwidth required. Connect the receiver or down-converter to the input of the LimeSDR and, on the “set-up” menu, adjust the Lime Gain so that the background (baseline) noise level is around -60 dB. Background noise levels below this are outside the linear range of measurement. Press the “establish baseline” button and the meter should read near zero.

Any increases in noise from the baseline level will then register on the meter. The spectrum plot allows interfering signals that may upset the reading to be seen.

The “DC spike” in the centre of the spectrum is rejected from the calculations; by default the calculations use the spectrum from 5% to 45% and 55% to 95% of the display width.

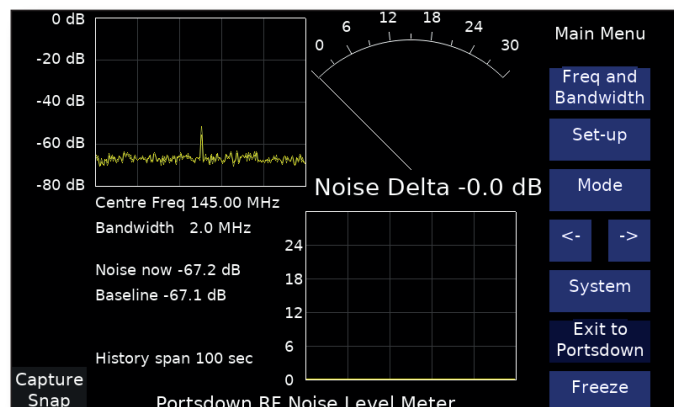

▶ Absolute mode

The meter scale can be changed through six ranges by touching the right and left halves of the meter face. The ranges are

- 0 to 30 dB (default)
- 20 to 30 dB
- 10 to 20 dB
- 0 to 10 dB
- 0 to 5 dB
- 5 to +5 dB

The meter reading is recorded on the history chart, which adopts the same scaling as the main meter. The default length of the history is 100 seconds. This can be changed from the second config menu (select “freq and bandwidth”, “config menu”, “more config”). The smoothing time for the noise reading can also be adjusted here.

Differential noise measurement

The differential noise measurement mode is selected from the mode menu and compares the noise level between two frequency ranges.

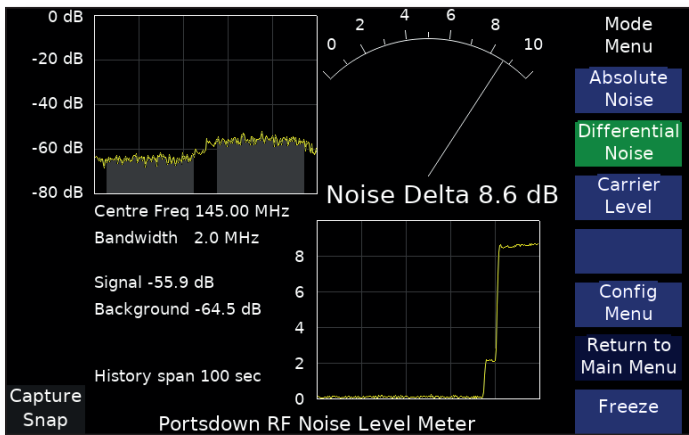

► *Differential mode*

The frequency ranges are indicated by the shaded areas below the trace on the spectrum and can be adjusted from the “freq and bandwidth”, “config menu”. The adjustment figures are percentages of the span width and are also applied to the absolute mode, so care is required to reset the values if using both modes.

One possible use for this mode is to optimise receiver and aerial matching while receiving a DATV test transmission on an antenna range.

Carrier level measurement

Carrier level modes are selected from the mode menu. Either the average level of noise in one frequency range is used as the reference, or the absolute level can be displayed. For average noise, the peak level of the strongest signal in the second frequency range is used for comparison.

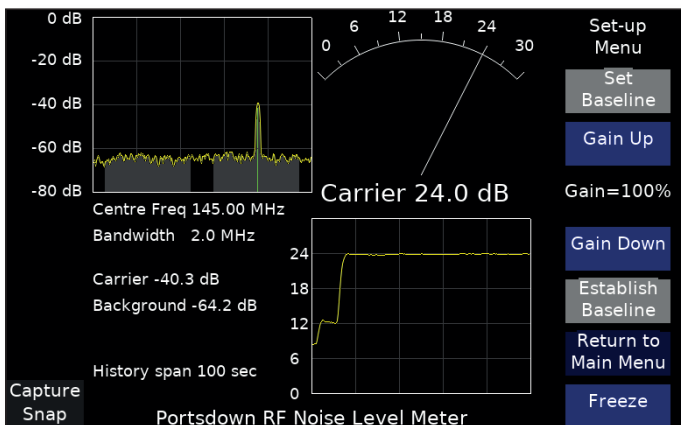

► *Carrier measurement mode*

The position of the peak is indicated by a green line. The time smoothing is automatically increased in this mode to obtain a stable reading suitable for use in the optimisation of systems.

A “flat top” windowing function is used to measure the peak amplitude, which provides an almost constant reading across two fft “bins”. While this is good for stability, there is a 4 dB reduction in apparent sensitivity compared to the Hanning windowing function used in the absolute and differential modes.

In Practice

Gareth G4XAT used the meter in absolute mode to measure the sun noise received using his QO-100 dish. He swept the dish across the sun and back again, resulting in the two peaks (with asymmetric sidelobes) visible on the history plot.

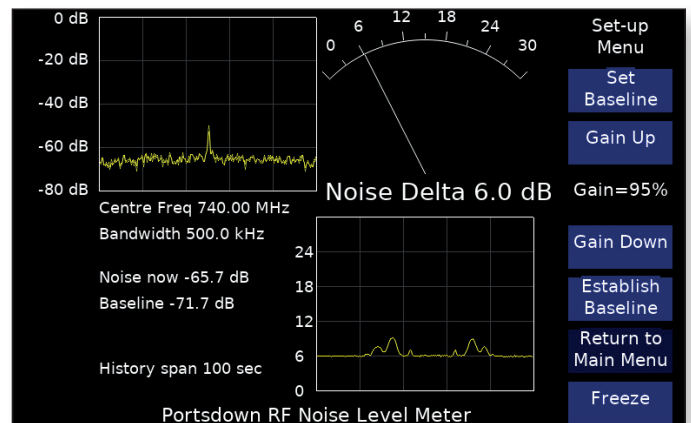

► *Sun noise measurement*

Conclusion

The Portsdown noise level meter provides an additional piece of test equipment at no cost to those of you who already have a Portsdown 4 with a LimeSDR Mini.

Please post on the BATC forum your experiences with using the capability; it would be good to have some feedback.

As it is a niche capability, I do not plan to extend the functionality to other SDRs or the Portsdown 2020. I'd rather spend the time adding additional functionality to the Portsdown suite of test equipment. 🗨️



Modifications to the Polycom VTC Table Microphone

Dave Crump, G8GKQ

A number of club members have purchased Polycom VTC equipment with 360 degree desk mics, and Roger G3IUZ kindly sent me one to see if I could modify it for stand-alone ATV use. The microphone units are tightly integrated with the digital VTC equipment and I soon realised that the only way forward would be to tap off the analog audio before it was digitised.

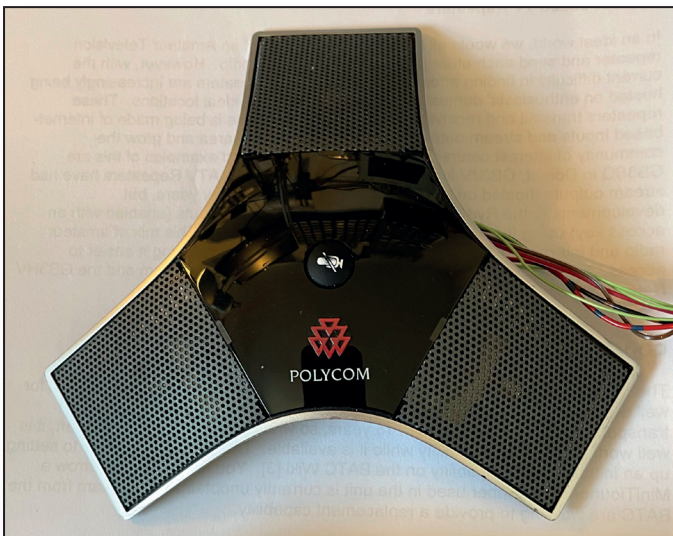

► The Polycom Microphone

Design

The 3 microphones go through 3 analog amplifiers before being presented to PCM1803A analog to digital converters. The digital audio is then passed to an FPGA for processing. We tap the audio at the input to the ADCs.

Disassembly

Remove the 3 screws on the underside of the unit. Unclip the top (silver) cover and put aside, together with the rubber mute button.

Lift the top PCB carefully and disconnect one of the microphone plugs (any one of the 3). Turn the top PCB over so that you can access it easily.

Supply wiring

The microphone needs between 7.5 and 12v at 35mA after this modification.

Carefully solder the ground of the supply wire to pin 1 (closest to J2) of VR4, then solder the positive supply to the input side (closest to the edge of the board) of L2. See the picture below.

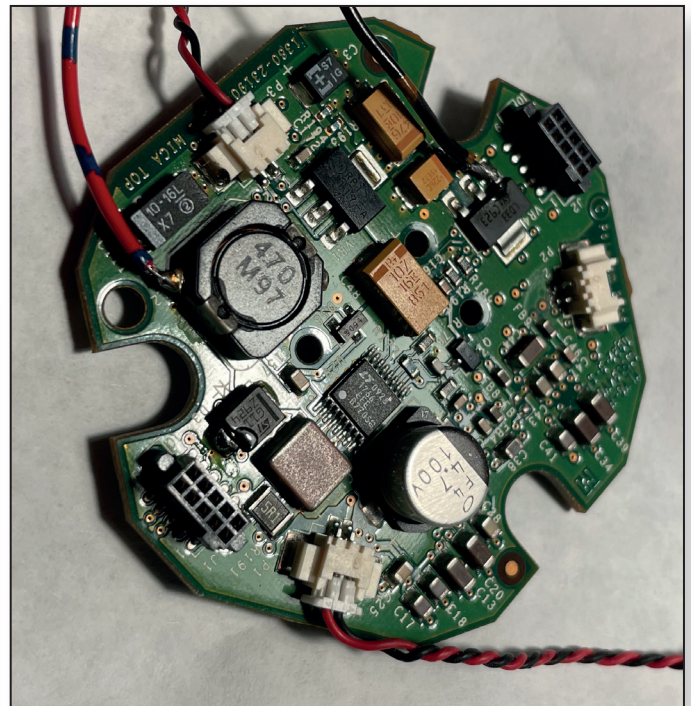

Connecting the supply voltage to the top PCB

Output wiring

The 3 amplified microphone output wires can then be soldered. The first on the side of C17 nearest to C25, the second on the adjacent C18, and the 3rd on the side of C38 nearest to C41. These are DC coupled around 2.5v.

The 5v used for the output driver can be tapped from pin 3 of VR4.

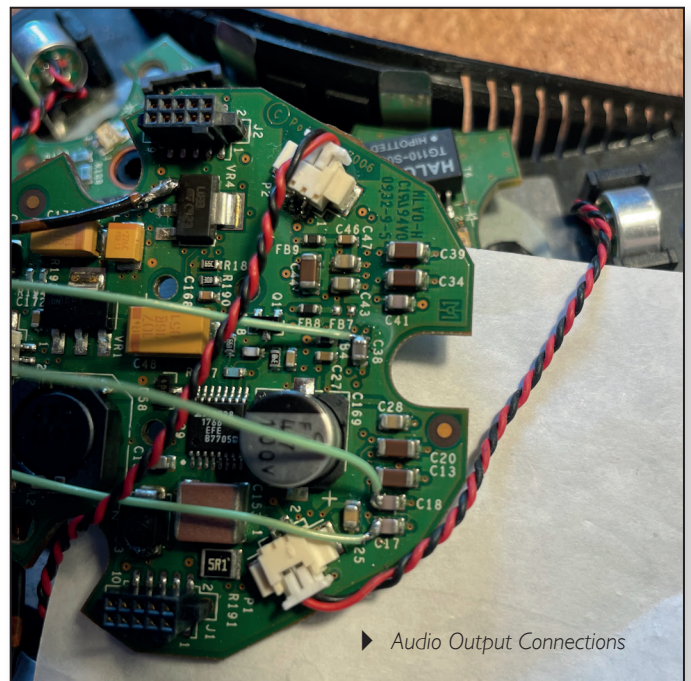

► Audio Output Connections

Closing the Unit

Route all the wires out of the socket on the side of the plastic case, reconnect the mic lead that was disconnected earlier (the red wire goes towards pin 1 on the socket) and put the top PCB back in its original position.

Rest the rubber button on top, and snap the silver plastic cover back into place. Replace the 3 screws.

Interfacing with Transmitters

The output on the microphone wires is about 50mV p-p at normal speech levels. This was insufficient to drive the “line” input on my ATEM Mixer, and I was also unhappy about exposing the outputs directly without some buffering. After some birds-nest experimentation, I settled on the circuit below, which has a voltage gain of 18, and a low enough output impedance to drive the ATEM Mixer. If your shack is particularly noisy, you may want to reduce the gain by reducing R1, R3 and R5

The odd choice of op-amps is because those were all I had in my junk box that would work with the single +5v supply. I am sure that there are a better/lower noise/more modern designs, but this was good enough for my use.

I chose to route the right and the left microphones to the right and left stereo channels, leaving the rearward facing microphone unused. Clearly there is a lot of scope for noise cancelling and other clever tricks.

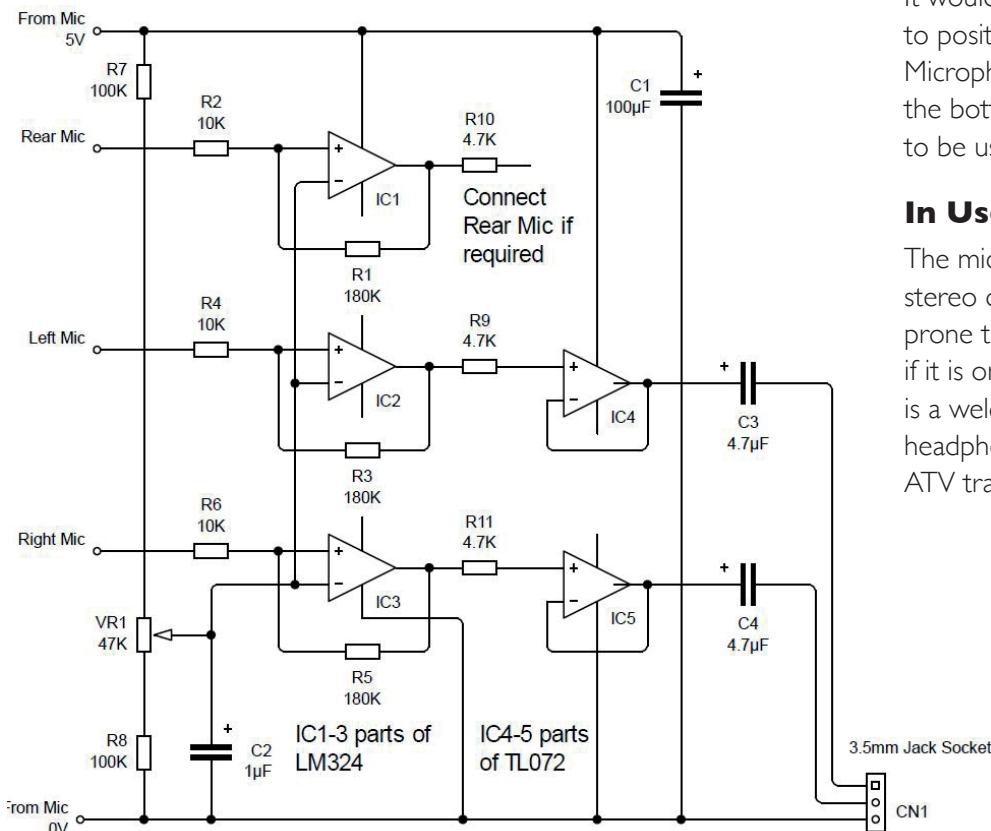

Polycom Mic Amp
G8GKQ 1 Feb 24

► Output Amplifier Schematic

Final Construction

After finalising the design, I rebuilt the output amplifier on veroboard and mounted it in a box connected to the microphone by a 5-core flying lead.

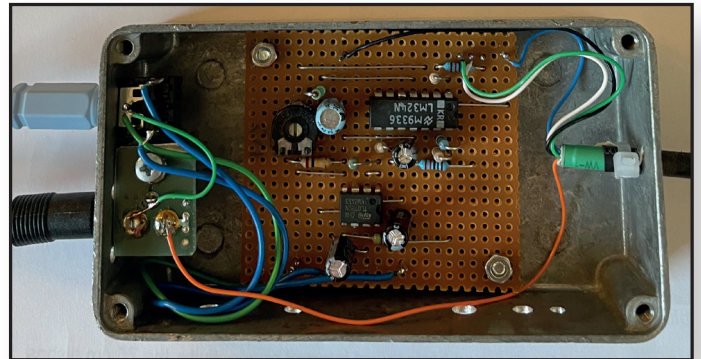

► The Finished Output Amplifier

Testing is easiest with an audio (loudspeaker) signal source. I used the excellent Electronic Toolbox on my iPhone which can play tones of any frequency at variable amplitude through the iPhone speaker. You can use this to identify the left and right microphones, and then adjust VR1 for symmetrical clipping when the microphone is overloaded. Incidentally, Electronic Toolbox includes many other useful tools and references in addition to the audio oscillator.

It would be possible to design a PCB to position the output amplifier in the Microphone case; this PCB would replace the bottom PCB which does not appear to be used in this application.

In Use

The microphone seems to give good stereo detection of voice, but is very prone to keyboard and mouse noises if it is on the same desk. However, it is a welcome alternative from using headphones with a boom mic for ATV transmissions. 🎧



32dB RF attenuator – an alternative solution...

Gareth, G4XAT

...and a lesson in referring to the datasheet!

The switched attenuator by Dave G8GKQ published in a recent CQ-TV set me thinking, not, as it turned out, entirely logically. Read on...

Although I have a pair of rotary 0-10dB in 1dB steps attenuators, a small lightweight unit with a greater range would be very handy, especially when trying to run multiple bands where the amps all need a different drive level, sometimes beyond a 10dB span. Many years ago I used the PICAXE range of microcontrollers (based on Microchip PICs but with a Basic interpreter factory installed) for a wide range of pupil friendly projects. My old website <http://www.g4xat.co.uk/> (untouched since 2013!) details what I dreamed up. One of the projects was a 'Binary Timer' which used an A to D input to choose the time delay and light a string of 8 LEDs (plus an activity LED) to display the time in binary. So 1-255 minute delays were possible, with a piezo sounder to play a tune on completion. It crossed my mind that it offered exactly what I wanted, a single rotary control to 'tune' the required attenuation. Rather than try and measure RF, I use an in-line DC watt-meter and set the drive to draw the required current previously determined (in the shack) as suitable for DATV. Well it works for me... less connector losses, less gear to forget...

The code needed some stripping out and the first implementation certainly worked after a style. However, a combination of using a compiled language and combining

two ports on the small Picaxe, (a 14M2) seemed to cause the attenuation to drop to max at every step change. The ever helpful Picaxe forum made some suggestions which went some way to cure the jumping. Turning up the clock speed also helped (a handy Picaxe feature as it can also be turned down to 32kHz for much reduced power consumption and up to 32MHz for speed-critical activity). It still wasn't right and after some pondering I concluded that it was probably because the 8 bit word was being written one bit at a time to two different ports – hardly a recipe for smooth transitions! I also wondered if I could/should use the enable pin on the attenuator to stop changes until after the 8 bit word had settled. When I first encountered the jumping, I posted my questions on the ever helpful Picaxe forum (<https://picaxeforum.co.uk/> - probably the best forum in the world... except perhaps for the BATC one!). As I made the code changes, I also checked the forum and there was a post suggesting that I checked the attenuator data sheet out – PE43703 (<https://picaxeforum.co.uk/threads/8-bit-binary-output-from-14m2-a-binary-timer.22532/>). In my haste to wire it all up, I'd mistakenly assumed that as there was an 8 bit switch fitted to the PCB, I needed 8 bit control lines. Well, yes, sort of... bit 7 was actually the P/S select line and the chip itself only needed 7 lines to select the attenuation. Well that's handy, I used the 8th bit to implement a settling delay followed by an enable pulse, blindingly obvious and all nicely documented in the data sheet. Such is the fun to be had with software and what can be learnt by referring to the data sheets or just doing the equivalent of RTFM.

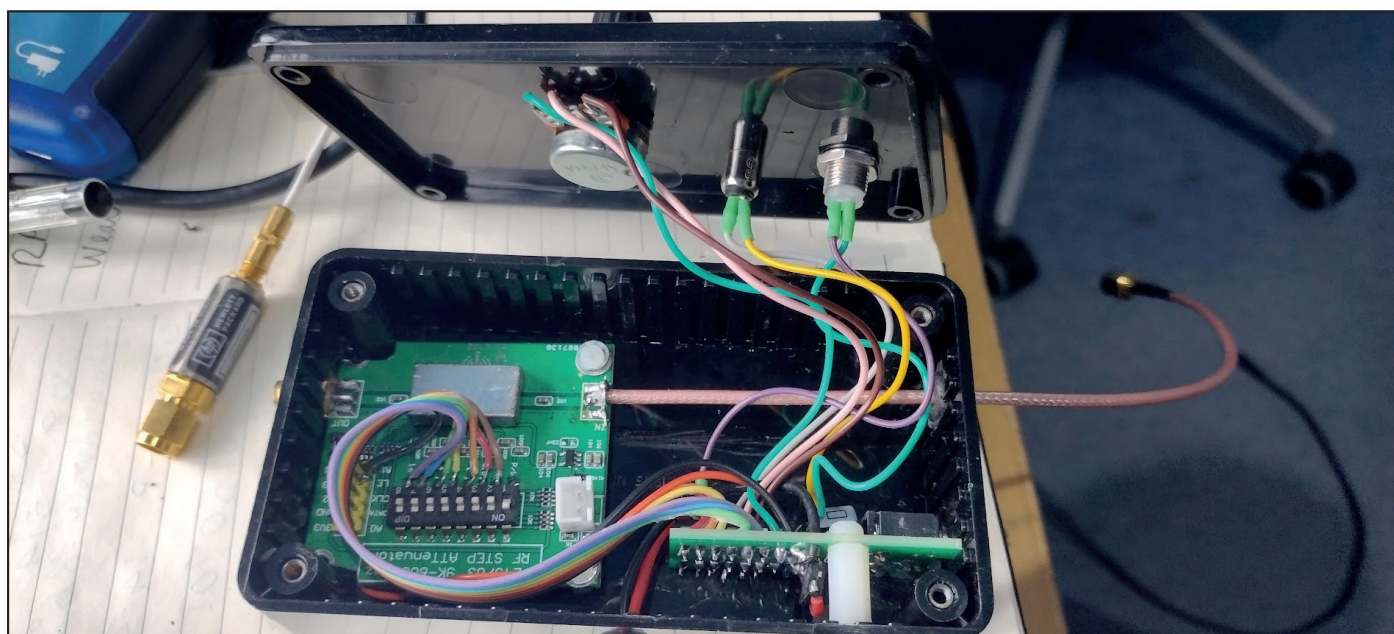

So now the “jobs a good ‘un” and I can progress the unit into a suitable enclosure. My attenuator board (eBay/China) came without any screening can over the actual chip so I salvaged a tiny tin cover from a defunct eBay pre-amp, one of the ‘DC to daylight’ specials and soldered it into place after scraping some resist off the ground plane.



If anyone would like the I4M2 PCB, I have 100's, left over from when I used to supply them to Rapid Electronics. I can also programme the Picaxe chips although I don't have any spares now.

Addendum... Rather than leave two pins unused, and to implement some semblance of safety (as Dave did by setting attenuation to maximum as a ‘first thing to do’ in software) I added an activity/mode LED and a push to make miniature switch. So at power up, maximum attenuation is set by default. Pressing the button for more than one second (so deliberate rather than accidental) lets you select the desired attenuation. When changing amps/bands, rather than rely on the user (me) turning the dial down to some low value, I wrote the software to reset to max attenuation and lock again until the button is pressed. OK, so you have to set the attenuation dial to max attenuation for this to happen, but it adds some interlocking. And it uses up all the pins, ‘tis in vain to do with more, that which can be done with less... 🗨

...And finally... the answer

Peter Delaney - G8KZG

The “And Finally” page-filler item in the last issue of CQTV generated quite a few replies. The first came from Jen, G4HIZ, and (in callsign order), Dave G0MXW, Mark G0NMY, Roger G3IUZ, John G1IMFN, Graham G3VKV, Nick G4IMO, Ray G4LUA, Jim G7NTG, Nigel G8AYC, Mike G8EEY, Graham G8VAT, Frank M0AEU, Matjaz S59MZ, Richard Ellis, Alan Rishworth, and Mike Willis also submitted ideas. The respondents included senior engineers from both the BBC and the manufacturing industry.

Some were light-hearted! One suggestion was that with valve bases at both ends, it was a ‘push-me pull-you – for push-pull amplifiers, of course’. Another also noticed that there are “input/output pins on both ends of the device whilst in the centre, you can see the expansion/reduction chamber. This device is used in both the transmission and reception chain of your transceiver to reduce your standard PAL composite signal to the new format narrowband 133KHz signal ready for transmission. On the reception end, the signal is received in the NB format, and expanded back up to the full PAL composite signal, for display on your CRT television”. A different suggested use was that it is an “apprentice clonker - when the apprentice came back late from lunch

or a tea break, the head engineer would give them a gentle clunk on the head for being so tardy” (A senior electronic design engineer informs the author that “such applications are done in software now”).

Most answers suggested that it was a picture scan converter; “one standard is displayed on a screen in the middle, a sensor running at a different rate then scans the image” – generically a Graphecon (a memory storage tube) being suggested. A common suggestion was that one end was a vidicon (although the dimensions of the device made the diameter of the device much larger than one of those). Specific uses suggested were to convert from one line standard to another, or to zoom in on a portion of the image. Other suggestions included a travelling wave tube, or a means to generate test card C.

The answer is that this is a TMA403X device, made by CSF in France. In the days before digital memory, tubes like this could be used to convert signals between scanning formats. At one end is what is basically a magnetically scanned cathode ray tube (without a phosphor screen), whilst at the other end is basically an electrostatically scanned iconoscope camera tube – both parts being electrostatically focussed. The crt (write) end puts a

pattern of charge onto a target layer at the middle of the device, which the camera tube (read) portion scans from the other side. One use of these was to convert an oscilloscope display into one that could be displayed by a standard television monitor – enabling, for example, captions to be added. A particular use of this type of tube was as a scan converter for radial radar plots to be shown on television screens. The device was able to reproduce half-tones, although the data sheet said those were “not to the quality of professional television” (and not the intended application for this particular device).

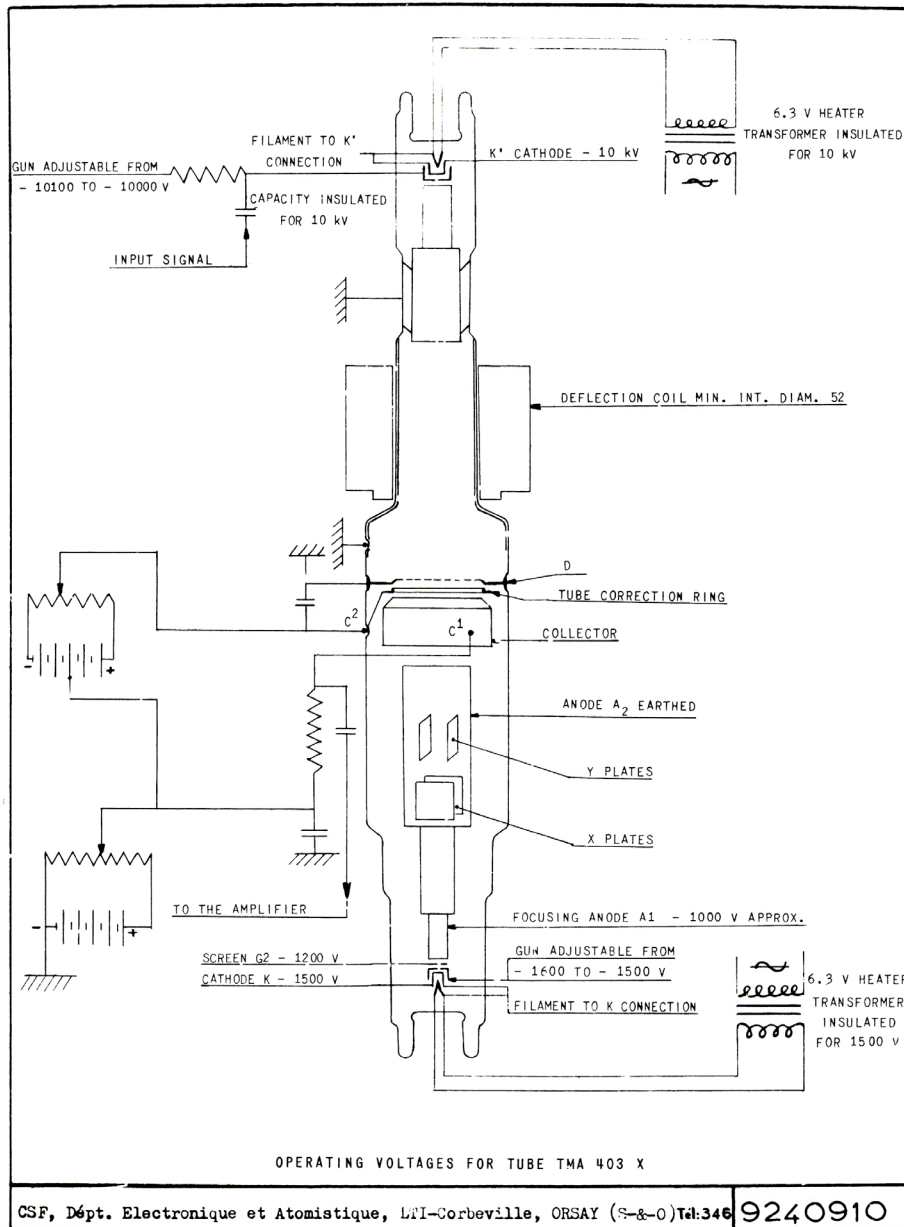

Was this a unique item? – No, as the photograph shows, there were a variety of scan converter tubes made. There are two of this type of tube in the centre, and at the bottom is a similar (but not interchangeable) device made by EMI, as its type 9759 used electrostatic deflection on the write side, and magnetic on the read side. At the top of the picture is a tube made by the Cathodeon company, which is even longer, but for which the input end of the device is much smaller in diameter (and looks vulnerable to damage!), and there were various other similar devices.

Thank you for all the ideas – serious and otherwise! Many of them were very close to the correct answer, with Dave GOMXW actually identifying the precise tube type – not surprising, as he had been a radar technician who had worked with them!

Turning Back the Pages

A dip into the archives of CQ-TV, looking at the issue of 48 years ago

Peter Delaney - G8KZG

CQ-TV 94

CQ-TV 94 appeared in May 1976, which was a BATC Convention year, so the front cover had a photograph of the main building of Leeds University,



where it was to be held in mid-September. Local amateurs were asked to contact Brian Summers (at that time the Club's Membership Secretary), if they were able to transmit ATV signals which could be received during the convention. The invitation was extended to both fast scan and slow scan stations. Those wishing to display equipment were also asked to contact Brian - "but as only five mains sockets are available for BATC's use, exhibitors offering to bring distribution boards will be given a greater welcome than those without!"

The first of the technical articles in this edition of the magazine was by Gordon Sharpley, G6LEE/T, when he described a simple piece of test equipment that might still be useful now. Gordon's 'Memory Logic Probe' was able to detect either positive or negative levels, and its 'memory facility' aided the detection of short pulses. Depending on the setting of the slide switch, the LED would light on either a logic 1 or a logic 0, and stay lit until the push button was pressed to cancel the display. If the memory facility was not needed, the button was kept depressed. Gordon had built this on Veroboard in a small plastic box, suggesting that the push button 'should be mounted convenient for the operator's thumb'.

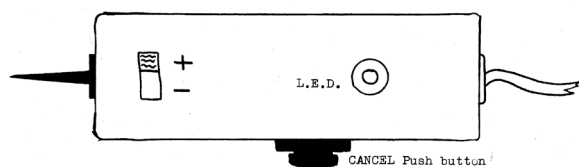
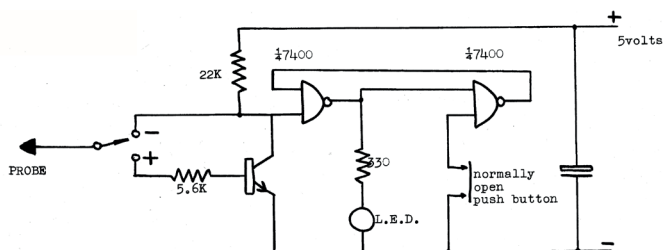

Recent Club projects for the reception of ATV signals have made use of the Serit FTS4334 or FTM4762 tuner modules to provide the front-end circuitry, amplifying the low-level signal from the aerial and tuning in the required transmission. The use of such 'tin-plate' boxes is not new, however. Domestic television receivers produced for the UHF channels used in the UK for the 625 line system used such modules.

Notable amongst those was the Mullard ELC1043 varicap tuner. The original version was popular with amateurs, as they would tune the amateur television 70cm band, without modification.

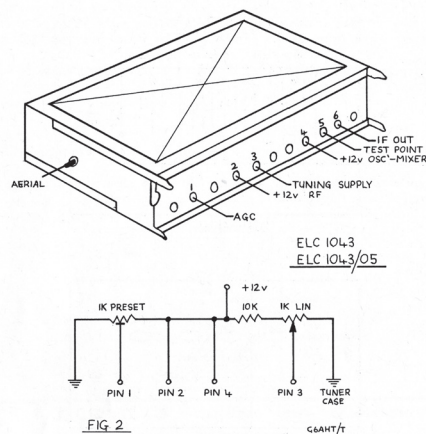

All that was needed was a 12V power supply and a clean variable low voltage of around 0.6V that controlled a varicap diode to tune in the desired signal. However, a revised low noise version, the ELC1043/05, did not

tune down quite far enough as to reach the 70cm atv allocation. A C Bevington, GAFV/T, and John Wood, G6AHT/T showed how a simple modification could be made to enable the low noise variant to be used for ATV work, adding a wire to each side of the oscillator and mixer

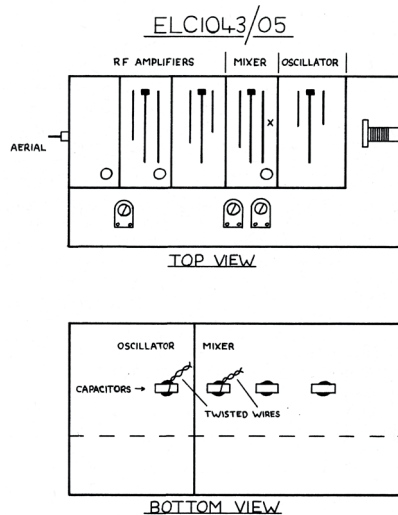

FIG 1

capacitors, and twisting each pair together, and adjusting a link in the mixer compartment (marked x on the top view in Fig 1) for maximum output. Figure 2 showed how either variant of the tuner needed to be wired up - a well-regulated supply being essential, as any variation in the voltage affected the tuning of course.

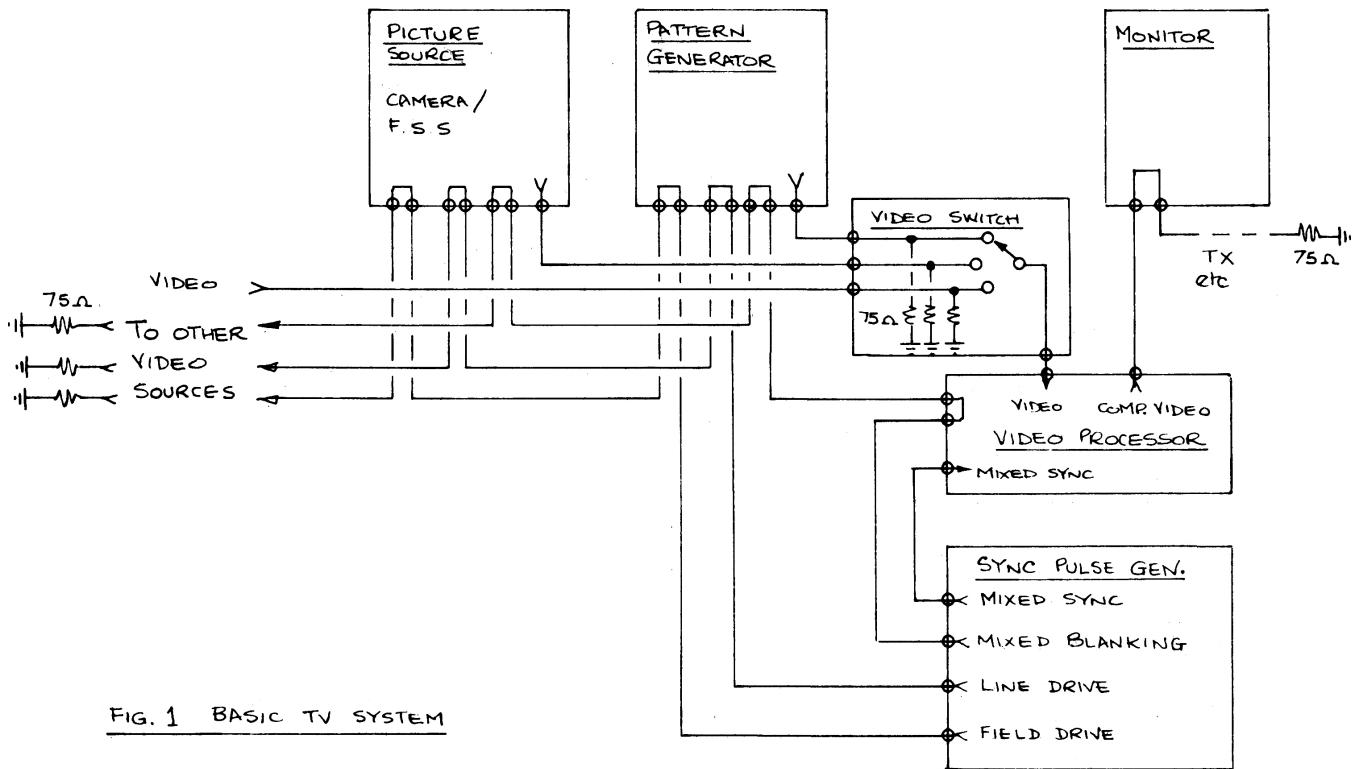

FIG. 1 BASIC TV SYSTEM

John Lawrence's "Circuit Notebook" series always contained sound practical ideas for amateur television. On this occasion he began by saying that "there are two units which are essential to any TV system, the picture source and the monitor or receiver", adding that the picture can originate from a number of different video sources, for example camera, flying spot scanner; monoscope, pattern generator, alpha-numeric generator, video recorder - and that "even in the most basic TV system it is useful to have two sources of video signal, one giving a 'picture' and one giving a test pattern. This will provide an alternative source of video signal whilst experimental work is being carried out on, say, the camera." John showed how the various units could be linked together in such a basic system.

All of the video sources (apart from a video recorder) would need to start each line and each frame of the image at the same time, and so were supplied with a common set of pulses from a sync pulse generator (SPG). The latter also supplied a video processing circuit, so that the blanking and synchronising pulses at the output are also timed to match. The coax cables carrying the pulse circuits were looped through each piece of equipment, each of which had a high impedance input circuit to tap off the pulse timings - a 75Ω resistor was put at the far end of the coax cable furthest from the SPG, to ensure a proper match and prevent pulses being reflected down the lead. (For the same reason, each video cable should also be terminated with a 75Ω resistor).

(Such terminating resistors may be built in to the equipment, or fitted to a loop-through connector).

A suitable input stage for the pulses at each piece of equipment was shown in Fig 2 (top), whilst a video output stage, capable of putting a 1V peak-to-peak video signal at the end of a properly terminated coax cable is shown in Fig 2 (bottom).

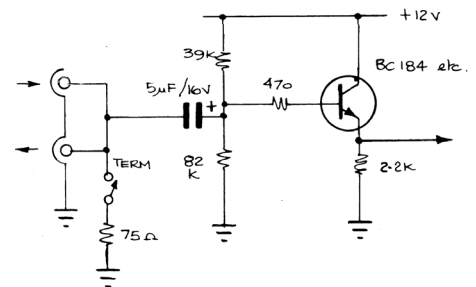

PULSE INPUT STAGE

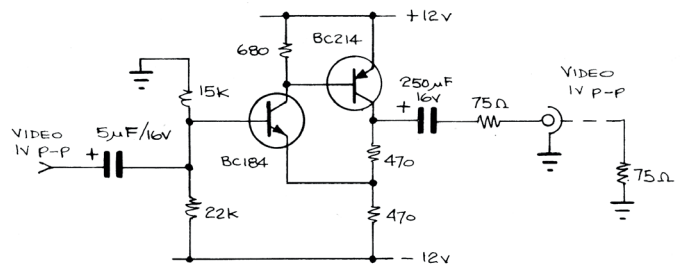

VIDEO OUTPUT STAGE

FIG 2.

Using an output stage like this works well if the video signal can be looped through each monitor, transmitter, etc in a similar way to that used to feed the pulse signals to each piece of equipment described earlier. However, it may not be convenient to send video signals to each monitor or other video circuit in this way, in which case a video distribution amplifier can provide sufficient drive for several terminated coax cables. John's article showed, with permission, such a circuit that had first appeared in the American "Electronics" magazine. The LM318 was a high-speed op-amp, whilst the LH10002 was a current driver with a flat response up to 4 MHz, with a small trimmer in the feedback loop to set the gain to be the same at 10 kHz and 1 MHz. The two amplifiers needed + and - supplies of 6.2V, and the article included a suitable power supply for those.

a complete new world awaits them, they can send video, audio both synced, even in colour!! He went on to discuss the problems of compatibility between the recording and playback machines. The alignment of the record/playback heads and the precise speed of the tape were the two main factors, to which he added the matter of dirty recording heads. He considered that the older reel-to-reel tape recorders had better speed stability than the later cassette machines. He suggested that the Club might produce a 'standard tape' for setting up the head alignment and tape speed. At that time, open reel domestic video recorders were available, with the VHS cassette system only being invented in 1976.

By coincidence, in the same issue, Grant Dixon wrote that he had been experimenting with the use of a stereo tape recorder, to capture the audio on one channel and sstv images on the other, and suggested that members adopt a standard format whereby the sound was on the stereo left and the video on the stereo right-hand channel.

Other topics raised by members included the possibility of having an FM repeater in the 70cm band - far and away the most used band for amateur television transmissions at the time. The Home Office and RSGB had already apparently agreed the frequencies to be used, and crystals had been purchased, without consulting BATC. It was reported that the Club had made protests at a Repeater Management Group meeting, but that they had fallen on deaf ears - the decisions had already been made. The letter writer suggested that amateur radio should be a 'construction' one, not a 'black box' one, the latter, in his view, being 'to the advantage of commerce who no doubt (he suggested) have pushed the idea anyway. Another member wrote that

the RSGB's Repeater Working Group had, it appeared to him, had a "high-handed and so-called compromise plan for 70cm repeaters", in which "they dismiss the activities of the Amateur Television Fraternity". At the time, transmissions of ATV in the 70cm band were wideband analogue, of course, so finding a wide enough part of the spectrum for amateur television transmissions was difficult, so other amateur activity in the band could have a serious impact on atv working. 📡

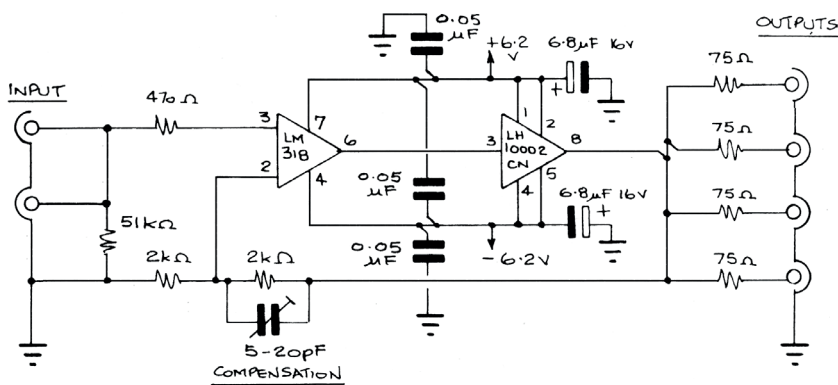

VIDEO DISTRIBUTION AMPLIFIER

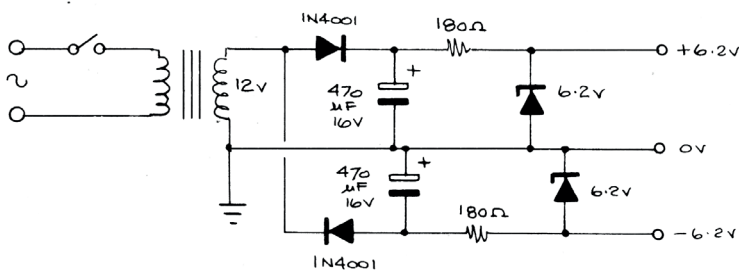

POWER SUPPLY

REPRINTED FROM ELECTRONICS FEB. 1976 COPYRIGHT © MC GRAW-HILL INC. 1976.

In an article entitled "Recorders, Heads and Things", J Brown, G3LPB, commented that the development of tape has made a completely different approach to modern living". Recorders (and tape was the only medium available for recording by amateurs at that time) he said had a multitude of uses - the conveying of the spoken word or music from one place to another, the conveying of knowledge from one source to another, and he suggested that with slow scan these ideas could be combined, to send pictures, patterns, knowledge and ideas, whilst for the rich fast scanners (his words!),

The British Amateur Television Club

The logo for the British Amateur Television Club (BATC) is a black trapezoidal shape with the letters 'BATC' in white, bold, sans-serif font. It is set against a blue background with a stylized white swoosh that curves around the top and right sides of the logo.

Out and About

Rallies and events with a BATC stand: (Provisional – subject to change)

14 April	Martlesham MRT	1 September	Telford HamFest (No shop)
21 April	Norbreck rally (No shop)	27/28 September	Newark Hamfest
23 June	Newbury rally	11/13 October	RSGB convention Milton Keynes
30 June	Dunstable Downs boot sale	13 October	Hornsea ARC rally (No shop)
14 July	McMichael rally Reading	26 October	BATC CAT 24 part two (online)
4 August	CAT 24 and general meeting	November	CATS bazaar
11 August	Flight Refuelling rally Wimborne	December	Midland MRT

Unless otherwise stated, the BATC Shop will be available at all these rallies and will be offering cheaper prices than online, and accepting card payments.

The most up to date status can be found on this RSGB web page: <https://rsgb.org/main/news/rallies/>

If you are able to help on the BATC Rally stands, please contact the BATC secretary.

Activity Weekends & Contests

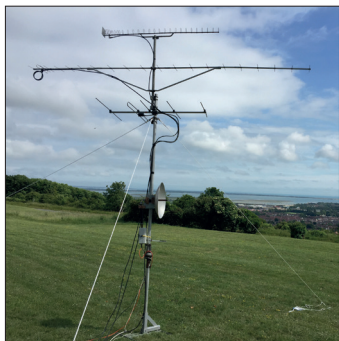

2024 Activity/Contest Weekends:

13/14 April	70cm
20/21 April	Dutch 6m, 2m and 70cm
11/12 May	All bands (IARU preparation)
8/9 June	IARU Region 1 ATV contest
6/7 July	2m, 4m and 6m
17/18 August	Dutch 6m, 2m and 70cm
7/8 September	13cm and up
5/6 October	70cm
2/3 November	2m, 4m and 6m
6/7 December	All bands

BATC Online

- Website:** <http://www.batc.org.uk>
BATC Wiki: <https://wiki.batc.org.uk/>
Forum: <https://forum.batc.org.uk/>
Stream: <https://batc.org.uk/live/>
Dxspot: <https://dxspot.batc.org.uk/>
YouTube: <https://tinyurl.com/BATCYouTube>

A screenshot of the British Amateur Television Club (BATC) website homepage. The header features the BATC logo and the text 'British Amateur Television Club'. Below the header is a navigation menu with links for HOME, JOIN BATC, MEMBERS, CQ-TV, SHOP, STREAMER, ON-LINE, CONTESTS & MAPS, EVENTS, and CLUB INFO. The main content area includes a welcome message, a 'Latest posts on BATC forum' section with several article thumbnails and titles, and a footer with a small text block.